

FUSIBLES NH XL PARA INSTALACIONES FOTOVOLTAICAS
NH XL FUSE-LINKS FOR PHOTOVOLTAIC INSTALLATIONS



gPV 1500 VDC

FICHA TÉCNICA / TECHNICAL DATA SHEET



DF ELECTRIC, S.A
C/. Silici, 67-69
08940 CORNELLA DEL LLOBREGAT
BARCELONA (SPAIN)
www.dfelectric.es
Telf.: +34-93 377 85 85
Fax: +34-93 377 82 82

ELECTRONIC
PROTECTION



INDUSTRIAL
PROTECTION
CYLINDRICAL



NH
INDUSTRIAL
PROTECTION



NF
DOMESTIC
PROTECTION



D
PROTECTION



DO
PROTECTION





RAPIDPLUS



TRANSFORMERS
AUTOTRANSFORMERS
CHOKES



<u>DESCRIPCIÓN DEL PRODUCTO</u>	<u>PRODUCT DESCRIPTION</u>
<p>Los cartuchos fusibles de cuchilla NH XL gPV 1500 V DC para instalaciones fotovoltaicas de DF Electric han sido desarrollados para ofrecer una solución de protección, en <i>arrays</i>, <i>subarrays</i> o en la entrada DC de los inversores de las instalaciones fotovoltaicas.</p> <p>La gama comprende cartuchos fusibles de tallas NH1XL, NH2XL y NH3L con corrientes asignadas comprendidas entre 40A y 400A</p> <p>La tensión asignada es de 1500 V DC.</p> <p>Disponibles en dos versiones de contacto, con cuchilla para montar en bases y versión para atornillar directamente sobre pletinas.</p> <p>Proporcionan protección contra sobrecargas y cortocircuitos (clase gPV de acuerdo a las Normas IEC60269-6 y UL248-19), con una corriente mínima de fusión de 1,35·In.</p> <p>Están contruidos con cuerpo de cerámica de alta resistencia a la presión interna y a los choques térmicos.</p> <p>Los contactos están realizados en cobre o latón plateado y los elementos de fusión son de plata, lo que evita el envejecimiento y mantiene inalterables las características.</p> <p>Tienen bajos valores de potencia disipada para una mejor eficiencia.</p> <p>UL Listed (File E355019) </p>	<p><i>NH gPV 1500 VDC fuse-links for photovoltaic installations from DF Electric have been developed to offer a safety protection solution in sub-array, array or inverter DC input of photovoltaic installations.</i></p> <p><i>The range comprises NH1XL, NH2XL and NH3L fuse-links with rated currents between 40A and 400A.</i></p> <p><i>Rated voltage is 1500 V DC.</i></p> <p><i>There are two versions of contacts, knife type to use in fuse-bases and bolted version to mount directly on busbar.</i></p> <p><i>They provide protection against overloads as well as short-circuits (gPV class according to IEC60269 and UL248-19 Standards, with a minimum fusing current of 1,35·In.</i></p> <p><i>Made with ceramic body with high withstand to internal pressure and thermal shock.</i></p> <p><i>Contacts are made in silver plated copper or brass and melting elements are made in pure silver in order to avoid the aging and thus keep unalterable the electric characteristics.</i></p> <p><i>They have a low power losses values to get a good efficiency.</i></p> <p>UL Listed (File E355019) </p>
<u>NORMAS</u>	<u>STANDARDS</u>
IEC60269-1 (Fusibles – requisitos generales) IEC60269-6 (Fusibles para sistemas fotovoltaicos) UL248-1 (Fusibles – requisitos generales) UL248-19 (Fusibles fotovoltaica) Directiva RoHS	<i>IEC60269-1 (Fuse-links – general requirements) IEC60269-6 (Fuse-links for solar photovoltaic systems) UL248-1 (Fuse-links – general requirements) UL248-19 (Photovoltaic fuses) RoHS compliant</i>
DF ELECTRIC se reserva el derecho a cambiar las dimensiones, especificaciones, materiales o el diseño de sus productos en cualquier momento sin previo aviso.	<i>DF ELECTRIC retains the right to change the dimensions, specifications, materials or design of its products at any time with or without notice.</i>

GAMA

RANGE

TALLA <i>SIZE</i>	CORRIENTE ASIGNADA (A) <i>RATED CURRENT (A)</i>	REFERENCIA CONTACTO CUCHILLA <i>REFERENCE KNIFE CONTACT</i>	REFERENCIA CONTACTO PARA ATORNILLAR <i>REFERENCE BOLTED CONTACT</i>	EMBALAJE <i>PACKAGING</i>
NH1 XL	40	372225 (UL)	372225B (UL)	1
	50	372230 (UL)	372230B (UL)	1
	63	372235 (UL)	372235B (UL)	1
	80	372240 (UL)	372240B (UL)	1
	100	372245 (UL)	372245B (UL)	1
	125	372250 (UL)	372250B (UL)	1
	160	372255 (UL)	372255B (UL)	1
	200	372260	372260B	1
NH2 XL	200	372350 (UL)	372350B (UL)	1
	250	372360 (UL)	372360B (UL)	1
NH3 L	315	372445 (UL)	372445B (UL)	1
	350	372448 (UL)	372448B (UL)	1
	355	372450 (UL)	372450B (UL)	1
	400	372455 (UL)	372455B (UL)	1

Microswitch NH000...NH3 * (250V 5A)	357010
* Only for knife contact models	



CARACTERÍSTICAS TÉCNICAS**TECHNICAL CHARACTERISTICS**

Tamaños <i>Sizes</i>	NH1XL – NH2XL - NH3L
Tensión asignada <i>Rated voltage</i>	1500V DC
Corrientes asignadas <i>Rated currents</i>	40A...200A (NH1XL) 200A...250A (NH2XL) 315A...400A (NH3L)
Poder de corte asignado <i>Rated breaking capacity</i>	30 kA (L/R = 2 ms)
Clase <i>Class</i>	gPV (protección de sobrecargas y cortocircuitos) (<i>protection against overload and short-circuit</i>)
Corriente mínima de interrupción <i>Minimum interrupt rating</i>	1,35·In
Corriente de no fusión <i>Non fusing current</i>	1,13·In
Temperatura de almacenaje <i>Storage temperature</i>	-40°C ... 90°C
Temperatura de funcionamiento <i>Operating temperature</i>	-40°C ... 80°C *

* Para temperaturas ambiente superiores a 25°C es necesario aplicar un coeficiente de corrección sobre la corriente máxima.

* *For ambient temperatures higher than 25°C it is necessary to apply a derating in maximum current.*

MATERIALES

Cuerpo	Cerámica
Cuchillas	Cobre o latón (plateadas)
Placas	Aluminio
Tornillería	Acero cincado

MATERIALS

<i>Body</i>	<i>Ceramics</i>
<i>Contact blades</i>	<i>Copper or brass (silver plated)</i>
<i>Plates</i>	<i>Aluminium</i>
<i>Screws</i>	<i>Zinc plated steel</i>

CARACTERÍSTICAS TÉCNICAS

TECHNICAL CHARACTERISTICS

TALLA	CORRIENTE ASIGNADA (A)	POTENCIA DISIPADA (W) @ 0,7·In	POTENCIA DISIPADA (W) @ In	I ² t PREARCO (A ² s)	I ² t TOTAL (A ² s)
SIZE	RATED CURRENT (A)	POWER DISSIPATION (W) @ 0,7·In	POWER DISSIPATION (W) @ In	PREARcing I ² t (A ² s)	OPERATING I ² t (A ² s)
NH1 XL	40	6,3	15	260	490
	50	7,2	18	560	1.170
	63	7,6	19	1.160	2.460
	80	10	25	1.760	3.720
	100	10,4	26	3.970	8.380
	125	12	30	7.070	14.900
	160	15	38	13.360	28.180
	200	19	47	24.850	52.400
NH2 XL	200	18	45	24.850	52.360
	250	21	52	42.000	88.500
NH3 L	315	25	61	114.000	172.080
	350	26	66	159.230	240.350
	355	27	68	159.230	240.350
	400	30	75	212.000	320.000

t _a (°C)	A ₁
25	1
30	0,98
35	0,95
40	0,92
45	0,90
50	0,87
55	0,85
60	0,82
65	0,79
70	0,76
75	0,72
80	0,69

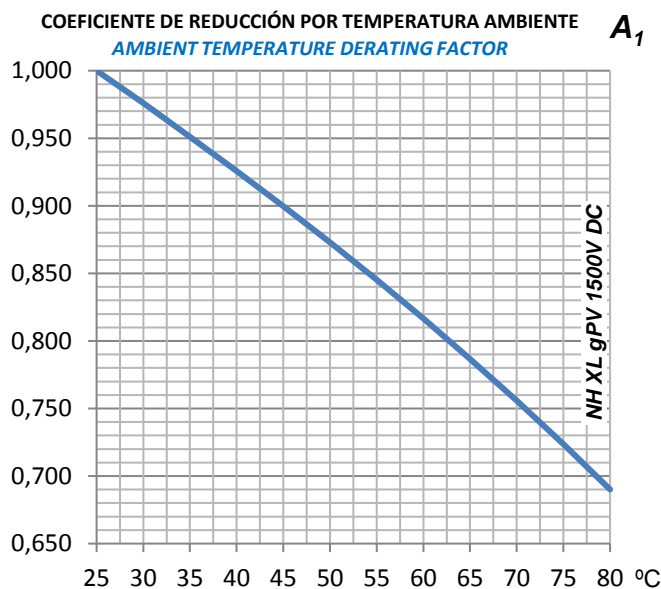

**CARACTERÍSTICAS TIEMPO-CORRIENTE
TIME-CURRENT CHARACTERISTICS**

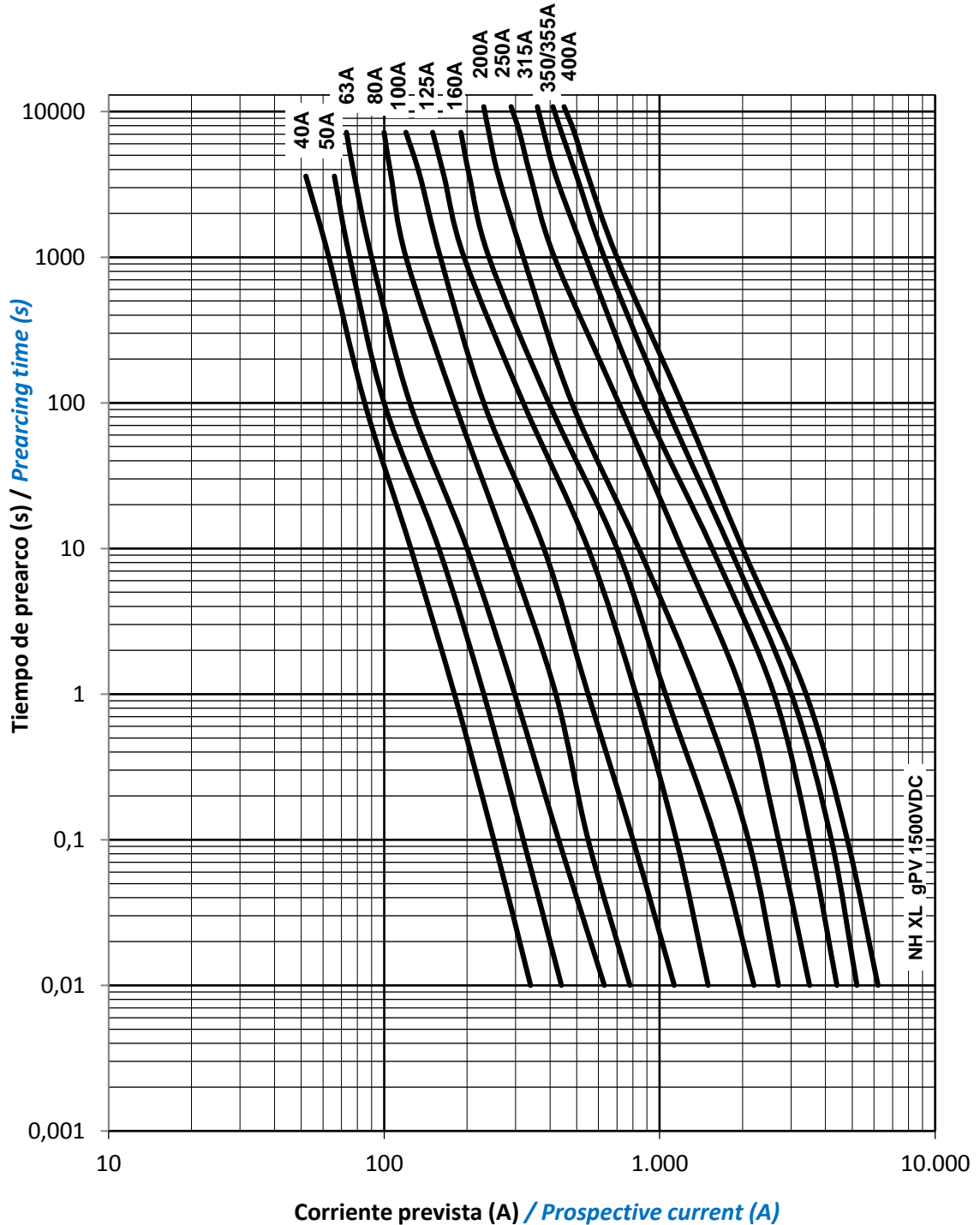

DIMENSIONES (mm)

DIMENSIONS (mm)

CONTACTO CUCHILLA / KNIFE CONTACT

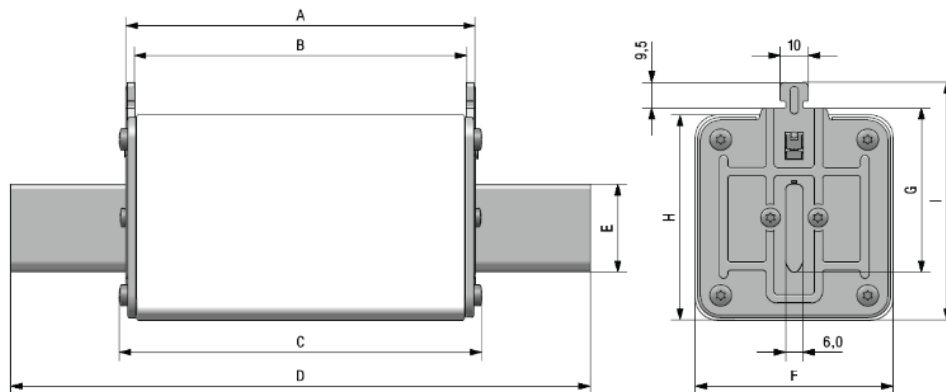

Talla / Size	A	B	C	D	E	F	G	H	I	Peso/weight
NH1 XL	126	120	129	191	20	39	40	52,5	64,5	0,65 kg
NH2 XL	122,6	117,6	126,7	205	25	53	48	60,5	72	0,99 kg
NH3 L	123,6	117,6	128,3	205	32	70	60	75	87	1,65 kg

CONTACTO PARA ATORNILLAR / BOLTED CONTACT

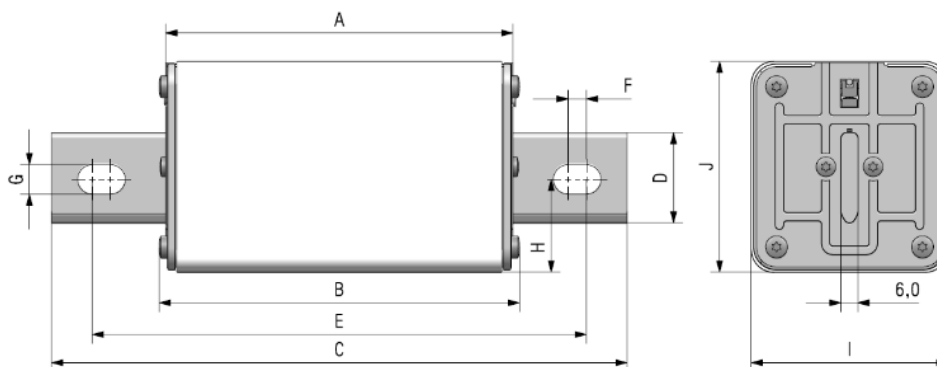

Talla / Size	A	B	C	D	E	F	G	H	I	J	Peso/weight
NH1 XL	126	129,0	191	20	170,5	9	8,5	25,6	39	52,5	0,64 kg
NH2 XL	122,6	126,7	205	25	173,0	9	10,5	27	53	60,5	0,98 kg
NH3 L	123,6	128,3	205	32	176,0	6,5	10,5	33	70	75,0	1,60 kg

Pares de apriete recomendados para los tornillos de conexión:

Recommended torque for connection screws:

NH1XL (M8): 10...12 Nm

NH2XL-NH3L (M10): 30...35 Nm

Distancia mínima recomendada entre fusibles:

Minimum recommended distance between fuse-links:

15 mm

GUÍA DE SELECCIÓN Y APLICACIÓN	SELECTION AND APPLICATION'S GUIDE
<p>En las centrales fotovoltaicas, se dan unas condiciones de instalación y de funcionamiento que deben ser consideradas a la hora de seleccionar el fusible adecuado para la protección.</p> <p>Estos fusibles suelen ir montados en el interior de cajas estancas, donde se alcanzan temperaturas ambiente elevadas. Esto obliga a reducir la corriente máxima a través de los fusibles ya que en caso contrario podría producirse la fusión prematura de los mismos. Para evitarlo, se deben aplicar unos coeficientes de reducción.</p> <p>Por otro lado, los ciclos día/noche y el paso de nubes hacen que la corriente varíe continuamente a través de los fusibles, generando continuos calentamientos y enfriamientos que producen stress térmico y mecánico en los materiales, especialmente en el elemento de fusión. Para evitar un posible envejecimiento prematuro que provoca la fusión intempestiva, debemos aplicar un coeficiente de seguridad (DF Electric recomienda un valor de 0,80 para este tipo de aplicaciones).</p> <p>Teniendo presentes estas consideraciones, podemos seleccionar el fusible más adecuado.</p> <p>Para verificar que la tensión asignada del fusible es adecuada debemos tener en cuenta los siguientes puntos:</p> <ul style="list-style-type: none"> • Tensión de circuito abierto de los módulos PV (V_{OC} STC) • Número de módulos conectados en serie (M). • Factor de seguridad (20%) para tener en cuenta el incremento de la tensión de vacío a temperaturas muy bajas. <p>Así, la tensión asignada en DC mínima de los fusibles debe ser:</p> $V_{DC\text{Fusible}} \geq V_{OC}(STC) \cdot M \cdot 1,2$ <p>La tensión de circuito abierto de los módulos V_{OC} (STC) es la tensión máxima que un módulo fotovoltaico puede dar cuando funciona en vacío (sin ninguna carga conectada) en unas condiciones de ensayo determinadas (STC = <i>Standard Test Condition</i>) y es un dato indicado por el fabricante de los módulos fotovoltaicos.</p>	<p><i>In photovoltaic plants, there are a special installation and working conditions that must be considered to select the appropriate protection fuse-links.</i></p> <p><i>These fuses are usually placed inside plastic watertight boxes, where high ambient temperatures are reached. This condition force to reduce the maximum current that can circulate through the fuse-links, otherwise it would be have premature aging. To avoid non-desired operation of fuse-links it is necessary to apply a derating when select the appropriate rated current.</i></p> <p><i>On the other hand, the day/night cycles as well as the pass of clouds cause a constant current changes that generates continuous heating and cooling, and this cause a thermal stress in fuse-links materials, especially in the melting elements. To avoid premature aging another derating must be applied (DF Electric recommend a value of 0,80 for this application).</i></p> <p><i>With these considerations it is possible to select the suitable fuse.</i></p> <p><i>To verify that the rated voltage of fuse-link is sufficient, the following points must be taken into account:</i></p> <ul style="list-style-type: none"> • <i>Open circuit voltage V_{OC} (STC) of PV modules.</i> • <i>Numbers of modules connected in series (M).</i> • <i>Safety factor (20%) to take into account the rise of open circuit voltage at very low temperatures.</i> <p><i>According to this, rated voltage in DC of fuse-links must be:</i></p> $V_{DC\text{Fusible}} \geq V_{OC}(STC) \cdot M \cdot 1,2$ <p><i>Open circuit voltage V_{OC} (STC) of PV modules is the maximum voltage that a Photovoltaic module can deliver when is working without load, measured under standard test conditions (STC). This information is given by the manufacturer of PV modules.</i></p>

Para escoger la corriente asignada del fusible a utilizar, los puntos a contemplar serán:

- Intensidad de cortocircuito de los módulos I_{SC} (STC)
- Número de *strings* conectados en paralelo (N_S)
- Factor de corrección de la temperatura ambiente (A_1).
- Factor de corrección por variación de la corriente (A_2).

La intensidad de cortocircuito de los módulos I_{SC} (STC) es la corriente máxima que un módulo fotovoltaico puede dar en unas condiciones de ensayo determinadas (STC) y es un dato indicado por el fabricante de los módulos fotovoltaicos.

Factor de corrección recomendado por variación de la corriente (A_2): 0,80.

La temperatura ambiente en el interior de las cajas donde se alojan las protecciones puede alcanzar fácilmente valores de 40°C ó 45°C (para climas tropicales hay que considerar valores más elevados). Se debe aplicar un factor de corrección (A_1) en función de la temperatura ambiente (ver tabla o gráfico de la página 5).

Con las consideraciones anteriores, la corriente asignada del fusible debe ser:

$$I_{N\text{fusible}} \geq \frac{I_{SC\ STC}}{A_1 \cdot A_2} \cdot N_S$$

Como ejemplo, si consideramos una temperatura ambiente máxima de 45°C, el calibre a utilizar sería:

$$I_{N\text{fusible}} \geq \frac{I_{SC\ STC}}{0,90 \cdot 0,80} \cdot N_S$$

$$I_{N\text{fusible}} \geq 1,40 \cdot I_{SC\ STC} \cdot N_S$$

To choose rated current of fuse-links, points to be taken into account are the following:

- *Short circuit current of PV modules I_{SC} (STC).*
- *Number of strings in parallel (N_S)*
- *Derating factor for ambient temperature (A_1).*
- *Derating factor for current variation (A_2).*

Short circuit current of PV modules $I_{SC\ STC}$ is the maximum current that one module can deliver measured under standard test conditions (STC). This data is also given by the manufacturer of PV modules.

Recommended derating factor for current variation (A_2): 0,80.

Ambient temperature inside boxes where are placed protections can reach easily 40°C or 45°C (for tropical countries it is necessary to consider higher values).

It should be applied a derating factor (A_1) as function of ambient temperature (see table or graphic in pag. 5).

With previous considerations, rated current of fuse-link should be:

$$I_{N\text{fuse_link}} \geq \frac{I_{SC\ STC}}{A_1 \cdot A_2} \cdot N_S$$

For example, if we consider a maximum ambient temperature of 45°C, the rating to use would be:

$$I_{N\text{fuse_link}} \geq \frac{I_{SC\ STC}}{0,90 \cdot 0,80} \cdot N_S$$

$$I_{N\text{fuse_link}} \geq 1,40 \cdot I_{SC\ STC} \cdot N_S$$