

FUSIBLES NH PARA INSTALACIONES FOTOVOLTAICAS
NH FUSE-LINKS FOR PHOTOVOLTAIC INSTALLATIONS

HORUS[®]
PHOTOVOLTAIC
PROTECTION



gPV 1000 VDC

FICHA TÉCNICA / TECHNICAL DATA SHEET



DF ELECTRIC, S.A

C/. Silici, 67-69

08940 CORNELLA DEL LLOBREGAT

BARCELONA (SPAIN)

www.dfelectric.es

Telf.: +34-93 377 85 85

Fax: +34-93 377 82 82

ELECTRONIC
PROTECTION



INDUSTRIAL
PROTECTION
CYLINDRICAL

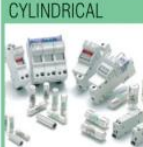

NH
INDUSTRIAL
PROTECTION



NF
DOMESTIC
PROTECTION



D
PROTECTION



DO
PROTECTION





RAPIDPLUS



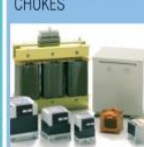







TRANSFORMERS
AUTOTRANSFORMERS
CHOKES



<u>DESCRIPCIÓN DEL PRODUCTO</u>	<u>PRODUCT DESCRIPTION</u>
<p>Los cartuchos fusibles de cuchilla NH gPV para instalaciones fotovoltaicas de DF Electric han sido desarrollados para ofrecer una solución de protección, en <i>arrays</i>, <i>subarrays</i> o en la entrada DC de los inversores de las instalaciones fotovoltaicas.</p> <p>La gama comprende cartuchos fusibles de tallas NH1, NH2 y NH3 con corrientes asignadas comprendidas entre 25A y 400A</p> <p>La tensión asignada es de 1000 V DC.</p> <p>Disponibles en dos versiones de contacto, con cuchilla para montar en bases y versión para atornillar directamente sobre pletinas.</p> <p>Proporcionan protección contra sobrecargas y cortocircuitos (clase gPV de acuerdo a la Norma IEC 60269-6 y UL248-19), con una corriente mínima de fusión de 1,35·In.</p> <p>Están contruidos con cuerpo de cerámica de alta resistencia a la presión interna y a los choques térmicos.</p> <p>Los contactos están realizados en cobre o latón plateado y los elementos de fusión son de plata, lo que evita el envejecimiento y mantiene inalterables las características.</p> <p>Para la instalación de estos fusibles se recomienda la utilización de la bases NH modelo ST de 1000VDC.</p> <p>Los fusibles con contacto a cuchilla están certificados UL.</p> <p>UL Listed (File E355019) </p>	<p><i>NH gPV fuse-links for photovoltaic installations from DF Electric have been developed to offer a safety protection solution in sub-array, array or inverter DC input of photovoltaic installations.</i></p> <p><i>The range comprises NH1, NH2 and NH3 fuse-links with rated currents between 25A and 400A.</i></p> <p><i>Rated voltage is 1000 V DC.</i></p> <p><i>There are two versions of contacts, knife type to use in fuse-bases and bolted version to mount directly on busbar.</i></p> <p><i>They provide protection against overloads as well as short-circuits (gPV class according to IEC 60269 and UL248-19 Standards, with a minimum fusing current of 1,35·In.</i></p> <p><i>Made with ceramic body with high withstand to internal pressure and thermal shock.</i></p> <p><i>Contacts are made in silver plated copper or brass and melting elements are made in pure silver in order to avoid the aging and thus keep unalterable the electric characteristics.</i></p> <p><i>For these fuse-links we recommend the utilization of 1000 VDC NH ST fuse bases.</i></p> <p><i>Fuse-links with knife contact version are UL approved.</i></p> <p>UL Listed (File E355019) </p>
<u>NORMAS</u>	<u>STANDARDS</u>
<p>IEC60269-1 (Fusibles – requisitos generales) IEC60269-6 (Fusibles para sistemas fotovoltaicos) UL248-1 (Fusibles – requisitos generales) UL248-19 (Fusibles fotovoltaica) Directiva RoHS</p>	<p><i>IEC60269-1 (Fuse-links – general requirements) IEC60269-6 (Fuse-links for solar photovoltaic systems) UL248-1 (Fuse-links – general requirements) UL248-19 (Photovoltaic fuses) RoHS compliant</i></p>
<p>DF ELECTRIC se reserva el derecho a cambiar las dimensiones, especificaciones, materiales o el diseño de sus productos en cualquier momento con o sin previo aviso.</p>	<p><i>DF ELECTRIC retains the right to change the dimensions, specifications, materials or design of its products at any time with or without notice.</i></p>

GAMA

RANGE

TALLA	CORRIENTE ASIGNADA (A)	REFERENCIA CONTACTO CUCHILLA	REFERENCIA CONTACTO PARA ATORNILLAR	EMBALAJE
SIZE	RATED CURRENT (A)	REFERENCE KNIFE CONTACT	REFERENCE BOLTED CONTACT	PACKING
NH1	25	373210 	373210B	1
	32	373215 	373215B	1
	40	373225 	373225B	1
	50	373230 	373230B	1
	63	373235 	373235B	1
	80	373240 	373240B	1
	100	373245 	373245B	1
	125	373250 	373250B	1
	160	373255	373255B	1
200	373260	373260B	1	
NH2	200	373350	373350B	1
	250	373360	373360B	1
NH3	200	373425 	373425B	1
	250	373435	373435B	1
	315	373445	373445B	1
	355	373450	373450B	1
	400	373455	373455B	1



CARACTERÍSTICAS TÉCNICAS

TECHNICAL CHARACTERISTICS

Tamaños <i>Sizes</i>	NH1 – NH2 - NH3
Tensión asignada <i>Rated voltage</i>	1000V DC
Corrientes asignadas <i>Rated currents</i>	25A...200A (NH1) 200A...250A (NH2) 200A...400A (NH3)
Poder de corte asignado <i>Rated breaking capacity</i>	30 kA (L/R = 2 ms)
Clase <i>Class</i>	gPV (protección de sobrecargas y cortocircuitos) (<i>protection against overload and short-circuit</i>)
Corriente mínima de interrupción <i>Minimum interrupt rating</i>	1,35·In
Corriente de no fusión <i>Non fusing current</i>	1,13·In
Temperatura de almacenaje <i>Storage temperature</i>	-40°C ... 90°C
Temperatura de funcionamiento <i>Operating temperature</i>	-40°C ... 80°C *

* Para temperaturas ambiente superiores a 25°C es necesario aplicar un coeficiente de corrección sobre la corriente máxima.
* For ambient temperatures higher than 25°C it is necessary to apply a derating in maximum current.

MATERIALES

Cuerpo	Cerámica
Cuchillas	Cobre o latón (plateadas)
Placas	Aluminio
Tornillería	Acero cincado

MATERIALS

<i>Body</i>	<i>Ceramics</i>
<i>Contact blades</i>	<i>Copper or brass (silver plated)</i>
<i>Plates</i>	<i>Aluminium</i>
<i>Screws</i>	<i>Zinc plated steel</i>

CARACTERÍSTICAS TÉCNICAS

TECHNICAL CHARACTERISTICS

TALLA	CORRIENTE ASIGNADA (A)	POTENCIA DISIPADA (W) @ 0,7·In	POTENCIA DISIPADA (W) @ In	I ² t PREARCO (A ² s)	I ² t TOTAL (A ² s)
SIZE	RATED CURRENT (A)	POWER DISSIPATION (W) @ 0,7·In	POWER DISSIPATION (W) @ In	PREARcing I ² t (A ² s)	OPERATING I ² t (A ² s)
NH1	25	5,2	12,5	62	94
	32	6,3	15,5	122	184
	40	6,7	16,6	302	454
	50	7,5	18,0	562	844
	63	8,2	20,0	1.210	1.815
	80	10,0	27,0	2.250	3.375
	100	11,0	28,0	4.000	6.000
	125	12,5	32,0	6.500	9.700
	160	10,0	25,0	10.300	19.800
NH2	200	11,4	28,0	18.700	36.400
	250	13,0	33,3	36.800	71.500
NH3	200	19,5	48,0	21.700	31.700
	250	20,5	51,5	41.000	60.000
	315	26,2	66,0	76.000	111.500
	355	18,0	46,5	74.700	130.700
	400	20,0	51,0	104.400	182.600

t _a (°C)	A ₁
25	1
30	0,98
35	0,95
40	0,92
45	0,90
50	0,87
55	0,85
60	0,82
65	0,79
70	0,76
75	0,72
80	0,69

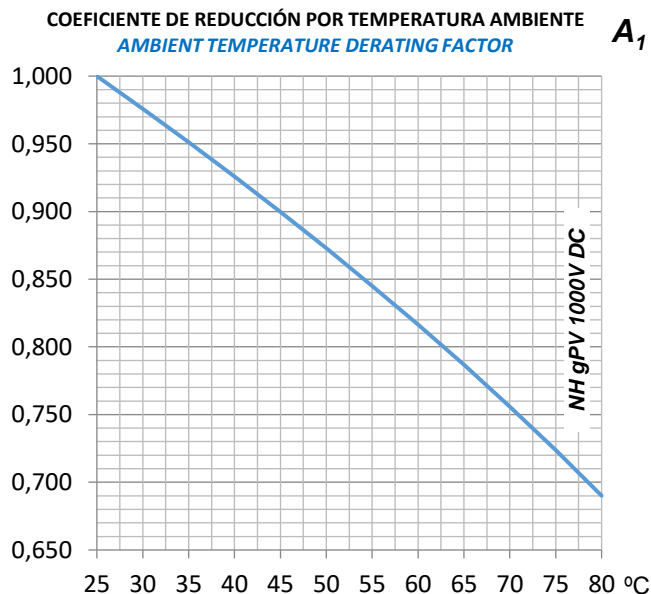

CARACTERÍSTICAS TIEMPO-CORRIENTE
TIME-CURRENT CHARACTERISTICS

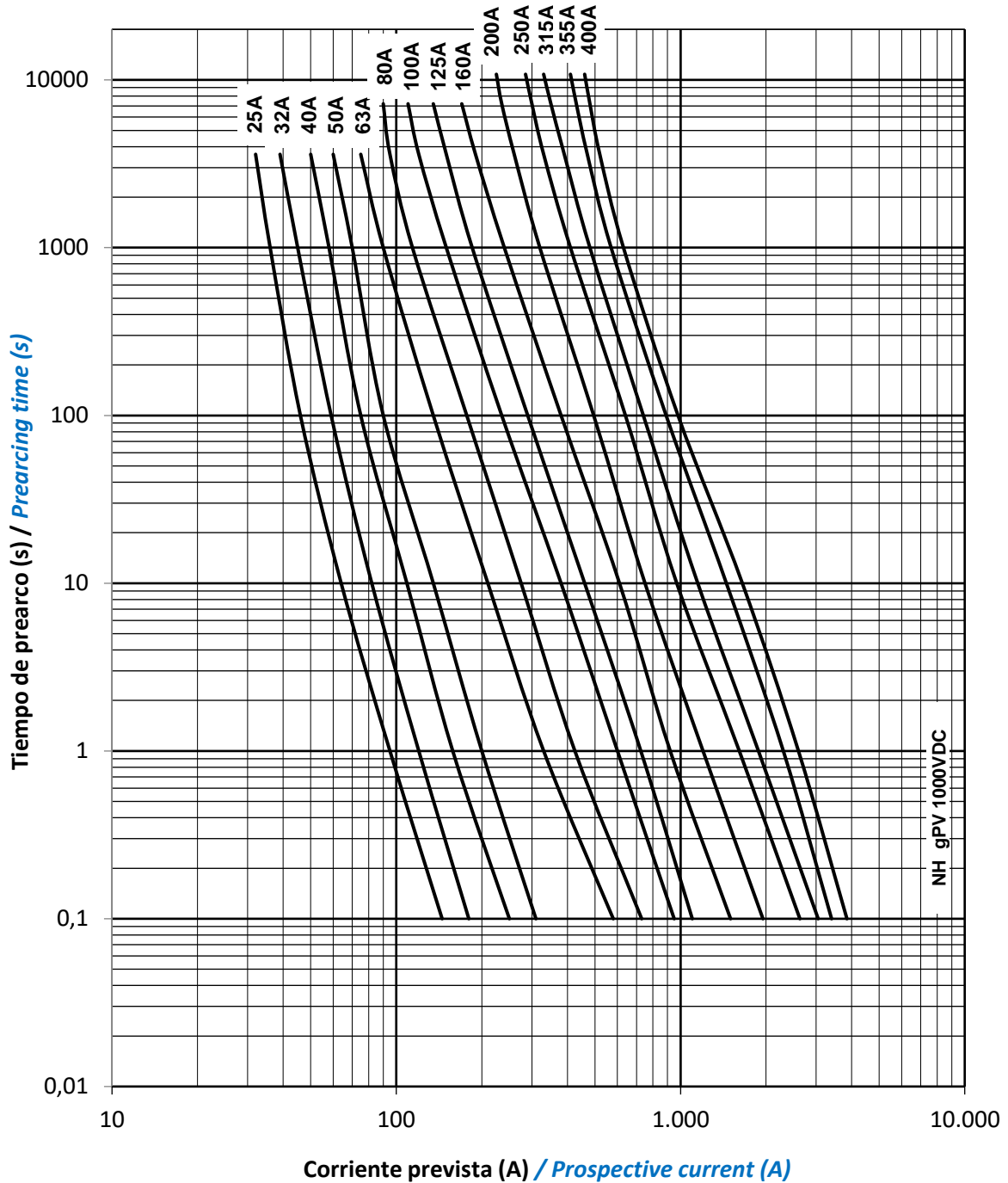

DIMENSIONES (mm)

DIMENSIONS (mm)

CONTACTO CUCHILLA / KNIFE CONTACT

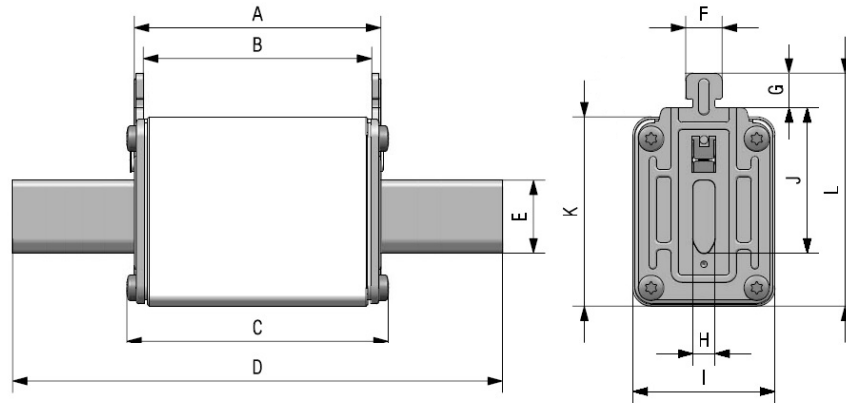

Talla / Size	A	B	C	D	E	F	G	H	I	J	K	L	Peso/weight
NH1	68	62	71,5	135	20	10	9,5	6	39	40	52	64	0,38 kg
NH2	68	62	71,5	150	25	10	9,5	6	53	48	60	72	0,62 kg
NH3	68	62	73	150	32	10	9,5	6	70	60	75	87	1,02 kg

CONTACTO PARA ATORNILLAR / BOLTED CONTACT

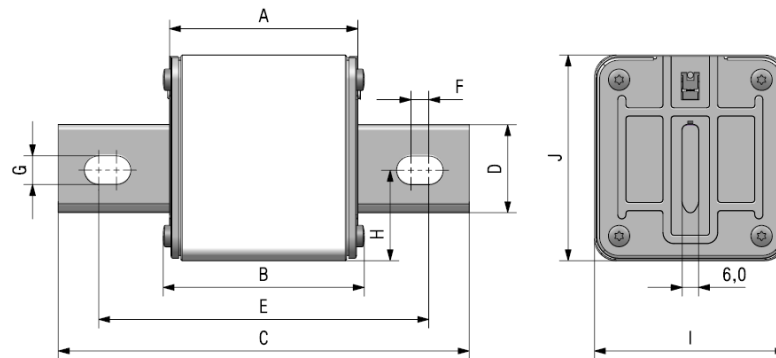

Talla / Size	A	B	C	D	E	F	G	H	I	J	Peso/weight
NH1	68	71,5	135	20	113	9	8,5	25,6	39	52,5	0,37 kg
NH2	68	71,5	150	25	118	9	10,5	27	53	60,5	0,61 kg
NH3	68	73	150	32	120	6,5	10,5	33	70	75,0	0,97 kg

Pares de apriete recomendados para los tornillos de conexión:
Recommended torque for connection screws:

NH1 (M8): 10...12 Nm
NH2 / NH3 (M10): 30...35 Nm

Distancia mínima recomendada entre fusibles:
Minimum recommended distance between fuse-links:

12 mm

GUÍA DE SELECCIÓN Y APLICACIÓN	SELECTION AND APPLICATION'S GUIDE
<p>En las centrales fotovoltaicas, se dan unas condiciones de instalación y de funcionamiento que deben ser consideradas a la hora de seleccionar el fusible adecuado para la protección.</p> <p>Estos fusibles suelen ir montados en el interior de cajas estancas, donde se alcanzan temperaturas ambiente elevadas. Esto obliga a reducir la corriente máxima a través de los fusibles ya que en caso contrario podría producirse la fusión prematura de los mismos. Para evitarlo, se deben aplicar unos coeficientes de reducción.</p> <p>Por otro lado, los ciclos día/noche y el paso de nubes hacen que la corriente varíe continuamente a través de los fusibles, generando continuos calentamientos y enfriamientos que producen stress térmico y mecánico en los materiales, especialmente en el elemento de fusión. Para evitar un posible envejecimiento prematuro que provoca la fusión intempestiva, debemos aplicar un coeficiente de seguridad (DF Electric recomienda un valor de 0,80 para este tipo de aplicaciones).</p> <p>Teniendo presentes estas consideraciones, podemos seleccionar el fusible más adecuado.</p> <p>Para verificar que la tensión asignada del fusible es adecuada debemos tener en cuenta los siguientes puntos:</p> <ul style="list-style-type: none"> • Tensión de circuito abierto de los módulos PV ($V_{OC\ STC}$) • Número de módulos conectados en serie (M). • Factor de seguridad (20%) para tener en cuenta el incremento de la tensión de vacío a temperaturas muy bajas. <p>Así, la tensión asignada en DC mínima de los fusibles debe ser:</p> $V_{DC\ Fusible} \geq V_{OC}(STC) \cdot M \cdot 1,2$ <p>La tensión de circuito abierto de los módulos $V_{OC}(STC)$ es la tensión máxima que un módulo fotovoltaico puede dar cuando funciona en vacío (sin ninguna carga conectada) en unas condiciones de ensayo determinadas (STC = <i>Standard Test Condition</i>) y es un dato indicado por el fabricante de los módulos fotovoltaicos.</p>	<p><i>In photovoltaic plants, there are a special installation and working conditions that must be considered to select the appropriate fuse-links.</i></p> <p><i>These fuses are usually placed inside plastic watertight boxes, where high ambient temperatures are reached. This condition force to reduce the maximum current that can circulate through the fuse-links, otherwise it would be have premature aging. To avoid non-desired operation of fuse-links it is necessary to apply a derating when select the appropriate rated current.</i></p> <p><i>On the other hand, the day/night cycles as well as the pass of clouds cause a constant current changes that generates continuous heating and cooling, and this cause a thermal stress in fuse-links materials, especially in the melting elements. To avoid premature aging another derating must be applied (DF Electric recommend a value of 0,80 for this application).</i></p> <p><i>With these considerations it is possible to select the suitable fuse.</i></p> <p><i>To verify that the rated voltage of fuse-link is sufficient, the following points must be taken into account:</i></p> <ul style="list-style-type: none"> • <i>Open circuit voltage $V_{OC\ STC}$ of PV modules.</i> • <i>Numbers of modules connected in series (M).</i> • <i>Safety factor (20%) to take into account the rise of open circuit voltage at very low temperatures.</i> <p><i>According to this, rated voltage in DC of fuse-links must be:</i></p> $V_{DC\ Fusible} \geq V_{OC}(STC) \cdot M \cdot 1,2$ <p><i>Open circuit voltage $V_{OC\ STC}$ of PV modules is the maximum voltage that a Photovoltaic module can deliver when is working without load, measured under standard test conditions (STC). This information is given by the manufacturer of PV modules.</i></p>

<p>Para escoger la corriente asignada del fusible a utilizar, los puntos a contemplar serán:</p> <ul style="list-style-type: none"> • Intensidad de cortocircuito de los módulos $I_{SC (STC)}$ • Número de <i>strings</i> conectados en paralelo (N_s) • Factor de corrección de la temperatura ambiente (A_1). • Factor de corrección por variación de la corriente (A_2). <p>La intensidad de cortocircuito de los módulos $I_{SC (STC)}$ es la corriente máxima que un módulo fotovoltaico puede dar en unas condiciones de ensayo determinadas (STC) y es un dato indicado por el fabricante de los módulos fotovoltaicos.</p> <p>Factor de corrección recomendado por variación de la corriente (A_2): 0,80.</p> <p>La temperatura ambiente en el interior de las cajas donde se alojan las protecciones puede alcanzar fácilmente valores de 40°C ó 45°C (para climas tropicales hay que considerar valores más elevados). Se debe aplicar un factor de corrección (A_1) en función de la temperatura ambiente (ver tabla o gráfico de la página 4).</p> <p>Con las consideraciones anteriores, la corriente asignada del fusible debe ser:</p> $I_{N \text{ fusible}} \geq \frac{I_{SC \text{ STC}}}{A_1 \cdot A_2} \cdot N_s$ <p>Como ejemplo, si consideramos una temperatura ambiente máxima de 45°C, el calibre a utilizar sería:</p> $I_{N \text{ fusible}} \geq \frac{I_{SC \text{ STC}}}{0,90 \cdot 0,80} \cdot N_s$ $I_{N \text{ fusible}} \geq 1,40 \cdot I_{SC \text{ STC}} \cdot N_s$	<p><i>To choose rated current of fuse-links, points to be taken into account are the following:</i></p> <ul style="list-style-type: none"> • <i>Short circuit current of PV modules $I_{SC \text{ STC}}$.</i> • <i>Number of strings in parallel (N_s)</i> • <i>Derating factor for ambient temperature (A_1).</i> • <i>Derating factor for current variation (A_2).</i> <p><i>Short circuit current of PV modules $I_{SC \text{ STC}}$ is the maximum current that one module can deliver measured under standard test conditions (STC). This data is also given by the manufacturer of PV modules.</i></p> <p><i>Recommended derating factor for current variation (A_2): 0,80.</i></p> <p><i>Ambient temperature inside boxes where are placed protections can reach easily 40°C or 45°C (for tropical countries it is necessary to consider higher values).</i></p> <p><i>It should be applied a derating factor (A_1) as function of ambient temperature (see table or graphic in pag. 4).</i></p> <p><i>With previous considerations, rated current of fuse-link should be:</i></p> $I_{N \text{ fuse_link}} \geq \frac{I_{SC \text{ STC}}}{A_1 \cdot A_2} \cdot N_s$ <p><i>For example, if we consider a maximum ambient temperature of 45°C, the rating to use would be:</i></p> $I_{N \text{ fuse_link}} \geq \frac{I_{SC \text{ STC}}}{0,90 \cdot 0,80} \cdot N_s$ $I_{N \text{ fuse_link}} \geq 1,40 \cdot I_{SC \text{ STC}} \cdot N_s$
---	---