

**FUSIBLES NH gS PARA LA PROTECCIÓN DE SEMICONDUCTORES**  
**NH gS HIGH SPEED FUSE-LINKS FOR SEMICONDUCTOR PROTECTION**

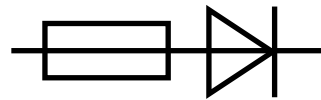

## RAPIDPLUS NH gS 800V

FICHA TÉCNICA / TECHNICAL DATA SHEET





### DF ELECTRIC, S.A

C/. Silici, 67-69  
08940 CORNELLA DEL LLOBREGAT  
BARCELONA (SPAIN)

[www.dfelectric.es](http://www.dfelectric.es)

Telf.: +34-93 377 85 85

Fax: +34-93 377 82 82

<ul style="list-style-type: none"> <li>● Los datos reflejados en esta ficha técnica están sujetos a la correcta instalación del producto de acuerdo con las instrucciones del fabricante, normas y reglamentos de instalación y conforme a las reglas profesionales, debidamente mantenidos y utilizados en las aplicaciones para las que está previsto.</li> <li>● Los productos descritos en este documento han sido diseñados, desarrollados y ensayados de acuerdo a una normativa específica. Se consideran componentes que son integrados formando parte de una instalación, máquina o equipo. La garantía y responsabilidad del correcto funcionamiento general del conjunto corresponde al fabricante de la instalación, máquina o equipo. DF Electric S.A. no puede garantizar las características de una instalación, máquina o equipo que ha sido diseñado por un tercero. Una vez que se ha seleccionado un producto, el usuario debe comprobar que es apropiado para su aplicación, mediante las verificaciones y/o ensayos que considere oportunos.</li> <li>● DF ELECTRIC se reserva el derecho a cambiar las dimensiones, especificaciones, materiales o el diseño de sus productos en cualquier momento con o sin previo aviso.</li> </ul>	<ul style="list-style-type: none"> <li>● <i>The data reflected in this technical data sheet are subject to the correct installation of the product in accordance with manufacturer's instructions, relevant installation standards and professional practices, maintained and used in applications for which they were made.</i></li> <li>● <i>The products described in this document have been designed, developed and tested in accordance with specific standard. They are considered components that are integrated as part of installation, machine or equipment. The correct general operation of the referred equipment is responsibility of the manufacturer of the installation, machine or equipment. DF Electric S.A. cannot guarantee the characteristics of an installation, machine or equipment that has been designed by a third party. Once a product has been selected, the user must verify that it is appropriate for its application, through the verifications and/or tests that it deems appropriate.</i></li> <li>● <i>DF ELECTRIC retains the right to change the dimensions, specifications, materials or design of its products at any time with or without notice.</i></li> </ul>
 <p>De acuerdo a la directiva de residuos de aparatos eléctricos y electrónicos (WEEE) el material eléctrico no debe formar parte de los residuos habituales. Este símbolo alerta a los usuarios de que estos productos deben reciclarse según la local medioambiental de eliminación de residuos.</p>	 <p><i>According to the waste of electrical and electronic equipment directive, electrical material should not be part of the usual waste. This symbol alerts users that these products should be recycled according to local environmental waste disposal regulations.</i></p>
 <p>El logotipo "experto electrotécnico" marcado sobre los productos incluidos en la presente ficha técnica indica que la instalación de estos productos debe ser realizada por personal experto con conocimientos especializados.</p>	 <p><i>The "electro technical expert" logo marked on the products included in this data sheet indicates that the installation of these products must be carried out by expert personnel with specialized knowledge.</i></p>
 <p>Para evitar riesgo eléctrico, realice la instalación sin tensión.</p>	 <p><i>To prevent electrical hazards, carry out the installation without voltage.</i></p>
 <p><a href="#">Advertencias de seguridad</a></p>	 <p><a href="#">Safety notice</a></p>

<b><u>DESCRIPCIÓN DEL PRODUCTO</u></b>	<b><u>PRODUCT DESCRIPTION</u></b>
<p>Los semiconductores son componentes electrónicos extremadamente sensibles a las sobrecargas y los cortocircuitos y no pueden protegerse mediante fusibles convencionales. Por ello existen fusibles para semiconductores, específicos para este fin, cuyos principales requisitos son la fusión rápida, unos bajos valores de energía (<math>i^2t</math>) y una adecuada coordinación selectiva con los dispositivos de protección aguas arriba.</p> <p>Los fusibles <b>RAPIDPLUS NH gS 800V</b> de <b>DF Electric</b> protegen en todo el rango de sobrecorrientes, tanto contra sobrecargas como contra cortocircuitos, con lo que además de proteger a los dispositivos semiconductores, también se protege a los cables y el resto de aparellaje de la instalación.</p> <p>Están optimizados para mantener unos valores bajos de potencia disipada, lo que permite que estos cartuchos fusibles sean montados en la mayoría de bases, seccionadores o interruptores con fusibles.</p> <p>Están disponibles en tallas NH00, NH1 y NH3, con una gama de corrientes asignadas comprendida entre 25A y 400A. La tensión asignada es de 800 V AC (+10%).</p> <p>Las aplicaciones típicas comprenden la protección de semiconductores (diodos, tiristores, triacs, etc) en inversores fotovoltaicos tipo <i>string</i>, rectificadores de potencia, SAI's, convertidores, variadores de velocidad de motores, arrancadores suaves, relés de estado sólido, inversores para soldadura y en general cualquier aplicación donde se precise proteger componentes semiconductores.</p>	<p><i>Semiconductors are electronic components extremely sensible to overloads and short-circuits, therefore they cannot be protected with general purpose fuse-links. For this reason there are high speed fuse-links for this specific purpose, with very fast melting characteristics, low let-through energy values (<math>i^2t</math>) and adequate selective coordination with protection devices upstream.</i></p> <p><i><b>RAPIDPLUS NH gS 800V</b> fuse-links from <b>DF Electric</b> are capable to clearing all types of overcurrents, overloads as well as short-circuits, thus the fuse links protect semiconductors as well as cables and all switchgear of installation.</i></p> <p><i>They are optimized to have reduced power dissipations that allow the utilization of a wide range of fuse-bases, disconnectors and fuse-switch-disconnectors.</i></p> <p><i>Available in sizes NH00, NH1 and NH3, with rated currents between 25A and 400A. The rated voltage is 800 V AC (+10%).</i></p> <p><i>Typical application comprise protection of semiconductors (diodes, thyristors, triacs, etc) used in photovoltaic string inverters, power rectifiers, UPS, converters, motor drives, soft starters, solid state relays, welding inverters and any application where it is necessary to protect semiconductor devices.</i></p>
<b><u>NORMAS</u></b>	<b><u>STANDARDS</u></b>
<p>IEC/EN 60269-1 (Fusibles – Requisitos generales) IEC/EN 60269-4 (Fusibles para protección de semiconductores) Directiva RoHS (Restricción de sustancias peligrosas)</p>	<p><i>IEC/EN 60269-1 (Fuses - General requirements) IEC/EN 60269-4 (Fuse-links for protection of semiconductors) RoHS directive (Restriction of Hazardous Substances)</i></p>

<b>GAMA</b>		<b>RANGE</b>																					
<table border="1"> <thead> <tr> <th>TALLA SIZE</th> <th>In (A)</th> <th>REF.</th> <th>EMBALAJE PACKAGING</th> </tr> </thead> <tbody> <tr> <td rowspan="7"><b>NH00</b></td> <td>25</td> <td>369030</td> <td rowspan="7"><b>3</b></td> </tr> <tr> <td>32</td> <td>369035</td> </tr> <tr> <td>40</td> <td>369045</td> </tr> <tr> <td>50</td> <td>369050</td> </tr> <tr> <td>63</td> <td>369055</td> </tr> <tr> <td>80</td> <td>369060</td> </tr> <tr> <td>100</td> <td>369065</td> </tr> </tbody> </table>				TALLA SIZE	In (A)	REF.	EMBALAJE PACKAGING	<b>NH00</b>	25	369030	<b>3</b>	32	369035	40	369045	50	369050	63	369055	80	369060	100	369065
TALLA SIZE	In (A)	REF.	EMBALAJE PACKAGING																				
<b>NH00</b>	25	369030	<b>3</b>																				
	32	369035																					
	40	369045																					
	50	369050																					
	63	369055																					
	80	369060																					
	100	369065																					
<table border="1"> <thead> <tr> <th>TALLA SIZE</th> <th>In (A)</th> <th>REF.</th> <th>EMBALAJE PACKAGING</th> </tr> </thead> <tbody> <tr> <td rowspan="4"><b>NH1</b></td> <td>100</td> <td>369245</td> <td rowspan="4"><b>3</b></td> </tr> <tr> <td>125</td> <td>369250</td> </tr> <tr> <td>160</td> <td>369255</td> </tr> <tr> <td>200</td> <td>369260</td> </tr> </tbody> </table>				TALLA SIZE	In (A)	REF.	EMBALAJE PACKAGING	<b>NH1</b>	100	369245	<b>3</b>	125	369250	160	369255	200	369260						
TALLA SIZE	In (A)	REF.	EMBALAJE PACKAGING																				
<b>NH1</b>	100	369245	<b>3</b>																				
	125	369250																					
	160	369255																					
	200	369260																					
<table border="1"> <thead> <tr> <th>TALLA SIZE</th> <th>In (A)</th> <th>REF.</th> <th>EMBALAJE PACKAGING</th> </tr> </thead> <tbody> <tr> <td rowspan="4"><b>NH3</b></td> <td>250</td> <td>369435</td> <td rowspan="4"><b>1</b></td> </tr> <tr> <td>315</td> <td>369445</td> </tr> <tr> <td>355</td> <td>369450</td> </tr> <tr> <td>400</td> <td>369455</td> </tr> </tbody> </table>				TALLA SIZE	In (A)	REF.	EMBALAJE PACKAGING	<b>NH3</b>	250	369435	<b>1</b>	315	369445	355	369450	400	369455						
TALLA SIZE	In (A)	REF.	EMBALAJE PACKAGING																				
<b>NH3</b>	250	369435	<b>1</b>																				
	315	369445																					
	355	369450																					
	400	369455																					
<table border="1"> <thead> <tr> <th></th> <th>REF.</th> <th>EMBALAJE PACKAGING</th> </tr> </thead> <tbody> <tr> <td><b>Microswitch NH000...NH3</b></td> <td><b>357010</b></td> <td><b>1</b></td> </tr> </tbody> </table>					REF.	EMBALAJE PACKAGING	<b>Microswitch NH000...NH3</b>	<b>357010</b>	<b>1</b>														
	REF.	EMBALAJE PACKAGING																					
<b>Microswitch NH000...NH3</b>	<b>357010</b>	<b>1</b>																					



<p><b>CARACTERÍSTICAS TÉCNICAS (Introducción)</b></p>	<p><b>TECHNICAL CHARACTERISTICS (Introduction)</b></p>
<p><b>COEFICIENTE DE CORRECCIÓN DE LA <math>i^2t</math></b></p> <p>Los valores de <math>i^2t</math> de funcionamiento indicados en las tablas corresponden a los valores más elevados que podemos tener cuando el fusible trabaja a su tensión asignada y un factor de potencia de 0,15-0,20. Se pueden calcular los valores correspondientes a tensiones inferiores multiplicando estos valores por el coeficiente de corrección <math>C_K</math>.</p> <p><b>POTENCIA DISIPADA</b></p> <p>Los valores de potencia disipada están indicados a la corriente asignada (<math>I_n</math>) y a <math>0,8 \cdot I_n</math> (80% de la corriente asignada). Se pueden calcular los valores de potencia correspondientes a otras intensidades mediante el coeficiente <math>C_p</math> de corrección de la potencia disipada en función del % de la corriente asignada. Este dato es muy importante para determinar las bases en las que pueden ser instalados estos fusibles. Es necesario que la potencia disipada del fusible en las condiciones de trabajo no sobrepase la potencia máxima que la base puede admitir.</p> <p><b>TENSIÓN DE ARCO <math>U_L</math></b></p> <p>Esta gráfica indica el valor de tensión de pico más elevado que puede presentarse en bornes del fusible durante su operación, en función de la tensión de trabajo.</p> <p><b>COEFICIENTE DE CORRECCIÓN POR TEMPERATURA AMBIENTE (<math>A_1</math>)</b></p> <p>Los valores de corriente asignada de los cartuchos fusibles están determinados por ensayos de tipo realizados a una temperatura ambiente de 25 °C. Cuando la temperatura de utilización es superior a este valor de referencia, la corriente máxima de trabajo la determinaremos multiplicando la corriente asignada del fusible por el factor de reducción <math>A_1</math>.</p>	<p><b><math>i^2t</math> TOTAL CLEARING CORRECTION FACTOR</b></p> <p><i>Total clearing <math>i^2t</math> values at rated voltage and at power factor of 0,15-0,20 are given in electrical characteristics tables. For other voltages, clearing <math>i^2t</math> values can be calculated multiplying these values by correction factor <math>C_K</math>.</i></p> <p><b>POWER DISSIPATION</b></p> <p><i>Power dissipation values are given at rated voltage (<math>I_n</math>) and at <math>0,8 \cdot I_n</math> (80% of rated current). It is possible to calculate values of power dissipation for other currents multiplying these values by correction factor <math>C_p</math> for power loss as a function of % of rated current. This value is very important to choose the appropriate fuse base to install these fuse-links. The power dissipation of fuse-link at the normal working conditions must be lower than the maximum value that the fuse base can withstand.</i></p> <p><b>ARC VOLTAGE <math>U_L</math></b></p> <p><i>This graphic gives the peak arc voltage <math>U_L</math> that can appear across the fuse link during operation as a function of working voltage.</i></p> <p><b>AMBIENT TEMPERATURE CORRECTION COEFFICIENT (<math>A_1</math>)</b></p> <p><i>Fuse current ratings are established by type tests with an ambient temperature of 25°C. When the utilization ambient temperature is higher than this reference value, the fuse-link must be “de-rated”. The rated current of fuse-link must be multiplied by a derating factor <math>A_1</math> to find the maximum operating current.</i></p>

**CARACTERÍSTICAS TÉCNICAS**

**TECHNICAL CHARACTERISTICS**

Tamaños: <i>Sizes:</i>	<b>NH00 - NH1 - NH3</b>
Tensión asignada: <i>Rated voltage:</i>	<b>800V AC +10%</b>
Corriente asignada: <i>Rated current:</i>	<b>25A...400 A</b>
Poder de corte asignado: <i>Rated breaking capacity:</i>	<b>120 kA</b>
Clase: <i>Operating Class:</i>	<b>gS</b>
Frecuencia asignada: <i>Rated frequency:</i>	<b>42...62 Hz</b>
Temperatura de trabajo: <i>Working temperature:</i>	<b>-40°C ... +80°C *</b>
Temperatura de almacenaje: <i>Storage temperature:</i>	<b>-40°C ... +90°C</b>

\* Para temperaturas ambiente superiores a 25°C es necesario aplicar un coeficiente de reducción sobre la corriente máxima.  
\* For ambient temperatures higher than 25°C it is necessary to apply a derating in maximum current.

**COEFICIENTE REDUCCIÓN A<sub>1</sub>  
(Temperatura ambiente)**

**A<sub>1</sub> DERATING FACTOR  
(Ambient temperature)**

t <sub>a</sub> (°C)	A <sub>1</sub>
25	1
30	0,98
35	0,95
40	0,92
45	0,90
50	0,87
55	0,85
60	0,82
65	0,79
70	0,76
75	0,72
80	0,69

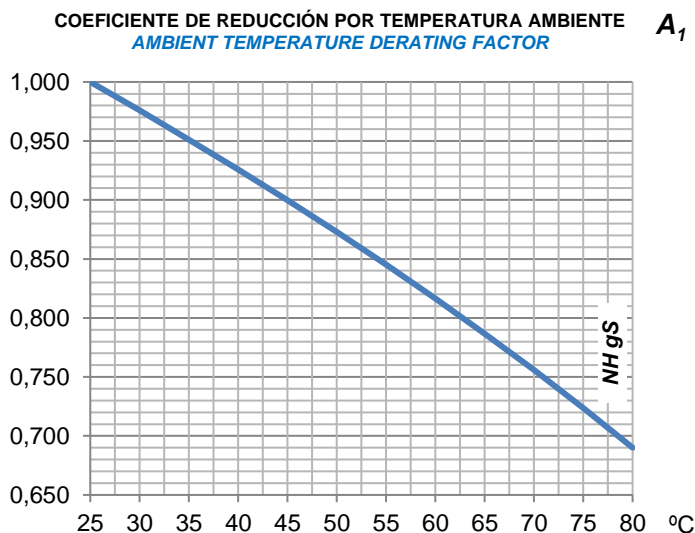

## CARACTERÍSTICAS TÉCNICAS

## TECHNICAL CHARACTERISTICS

Tamaño <i>Size:</i>	<b>NH00</b>
Clase <i>Class:</i>	<b>gS</b>
Tensión asignada <i>Rated voltage:</i>	<b>800 V ~</b>
Poder de corte asignado: <i>Rated breaking capacity:</i>	<b>120 kA</b>

In	$I^2t$ prearco <i>Prearcing <math>I^2t</math></i>	$I^2t$ total @ 800V <i>Operating <math>I^2t</math> @ 800V</i>	Potencia disipada 0,8·In <i>Power loss 0,8·In</i>	Potencia disipada In <i>Power loss In</i>
(A)	(A <sup>2</sup> s)	(A <sup>2</sup> s)	(W)	(W)
<b>25</b>	60	300	2,4	4,1
<b>32</b>	150	800	2,6	4,6
<b>40</b>	200	1.300	3,3	5,6
<b>50</b>	500	2.500	3,7	6,1
<b>63</b>	900	5.000	4,2	6,8
<b>80</b>	1.800	9.800	4,8	8,3
<b>100</b>	3.100	16.200	6,8	10,9



COEFICIENTE CORRECCIÓN  $i^2t$   
 $I^2t$  CORRECTION FACTOR

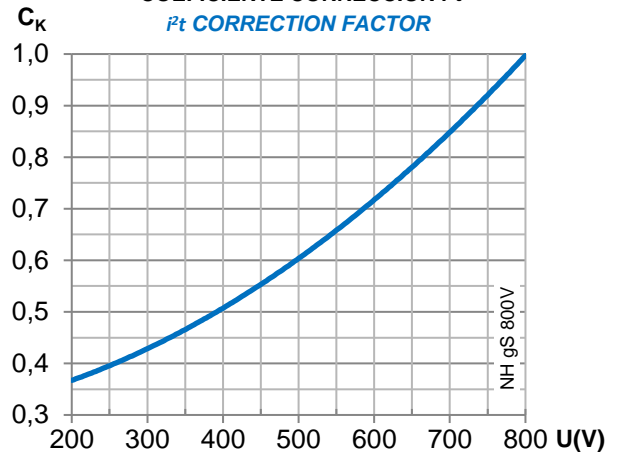

COEFICIENTE CORRECCIÓN DE LA POTENCIA DISIPADA  
CORRECTION FACTOR FOR POWER LOSS

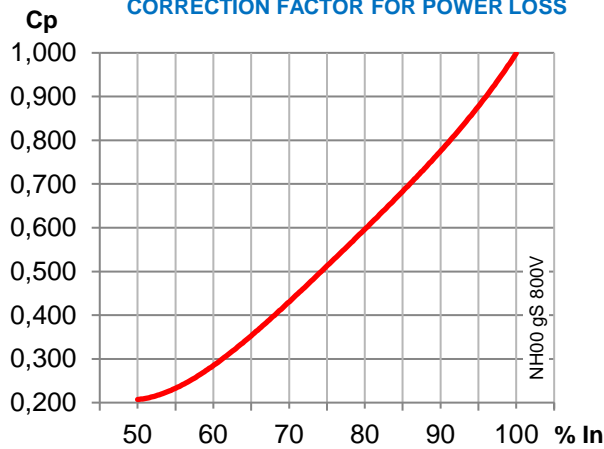

TENSIÓN DE ARCO  
PEAK ARC VOLTAGE

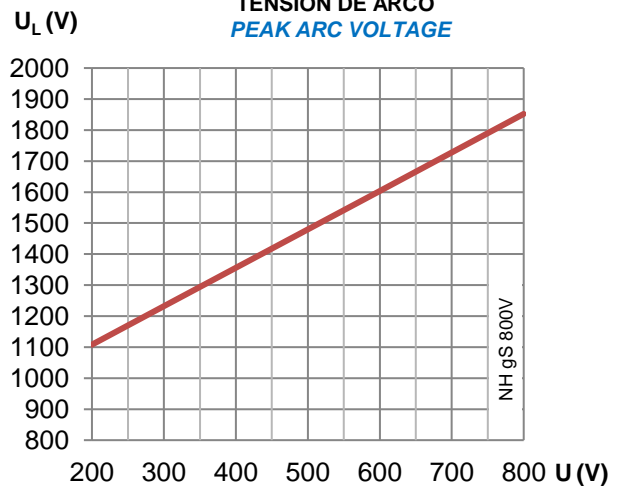

CARACTERÍSTICAS TÉCNICAS

TECHNICAL CHARACTERISTICS

CARACTERÍSTICAS TIEMPO-CORRIENTE  
TIME-CURRENT CHARACTERISTICS

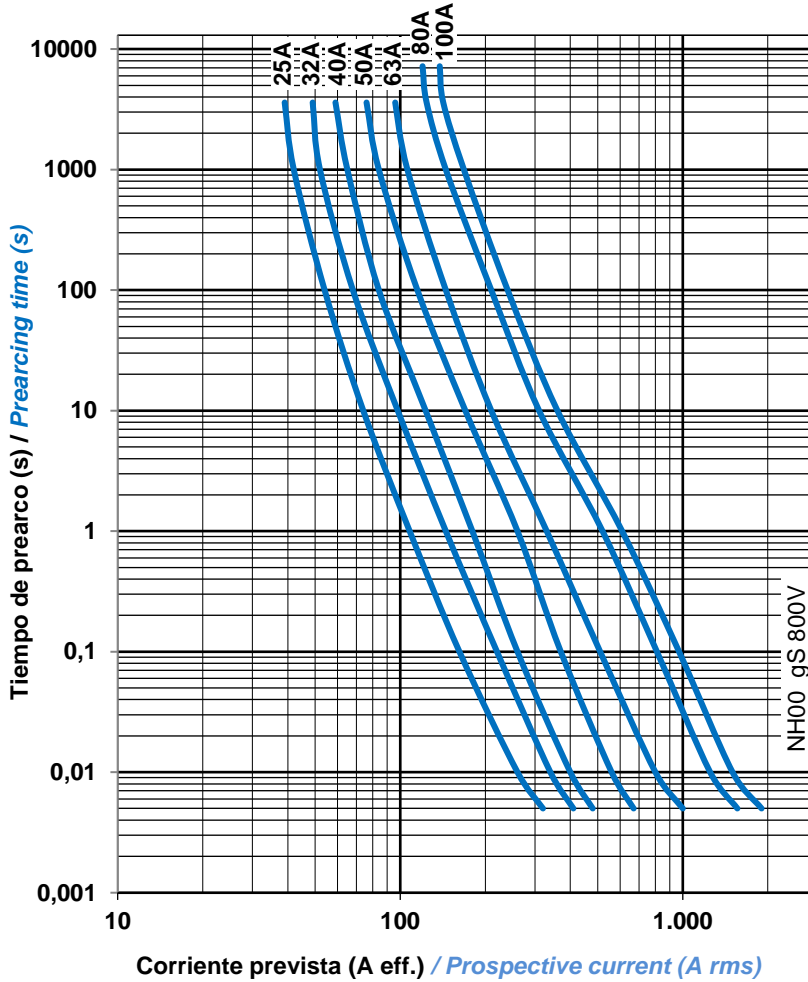

CARACTERÍSTICAS DE LIMITACIÓN  
CUT-OFF CHARACTERISTICS

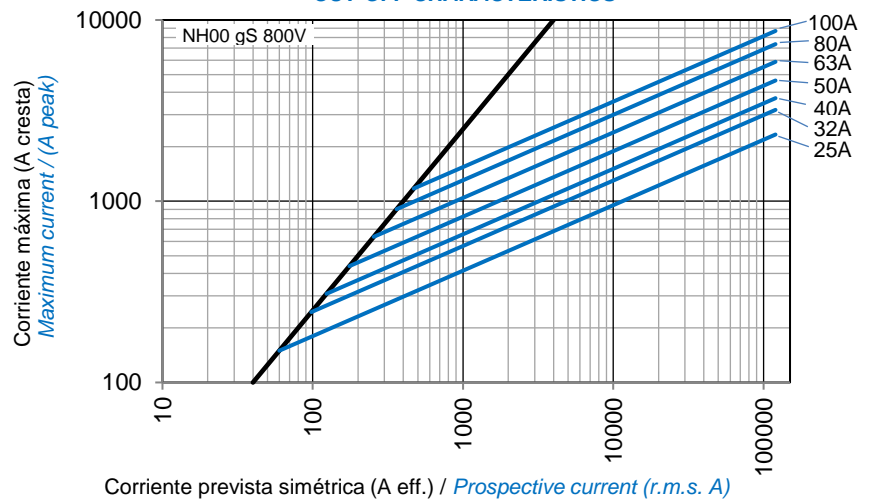

## CARACTERÍSTICAS TÉCNICAS

## TECHNICAL CHARACTERISTICS

Tamaño <i>Size:</i>	<b>NH1</b>
Clase <i>Class:</i>	<b>gS</b>
Tensión asignada <i>Rated voltage:</i>	<b>800 V ~</b>
Poder de corte asignado: <i>Rated breaking capacity:</i>	<b>120 kA</b>

	$I^2t$ prearco	$I^2t$ total @ 800V	Potencia disipada 0,8·In	Potencia disipada In
In	<i>Prearcing <math>I^2t</math></i>	<i>Operating <math>I^2t</math> @ 800V</i>	<i>Power loss 0,8·In</i>	<i>Power loss In</i>
(A)	(A <sup>2</sup> s)	(A <sup>2</sup> s)	(W)	(W)
<b>100</b>	2.300	7.900	8,5	14,5
<b>125</b>	4.600	15.400	9,4	16,0
<b>160</b>	9.400	31.500	10,8	18,5
<b>200</b>	18.400	61.800	12,0	20,5

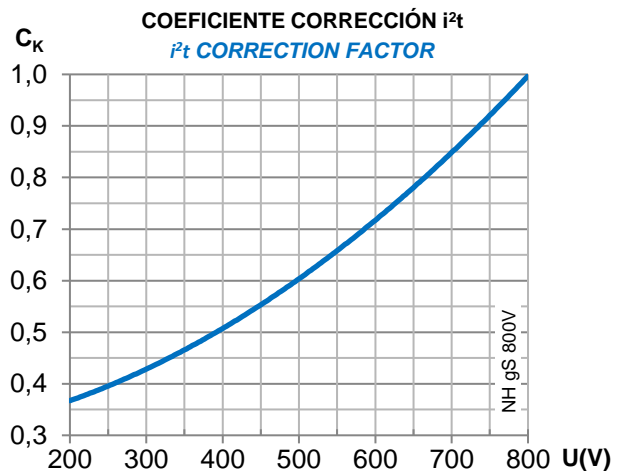

**COEFICIENTE CORRECCIÓN DE LA POTENCIA DISIPADA**  
*CORRECTION FACTOR FOR POWER LOSS*

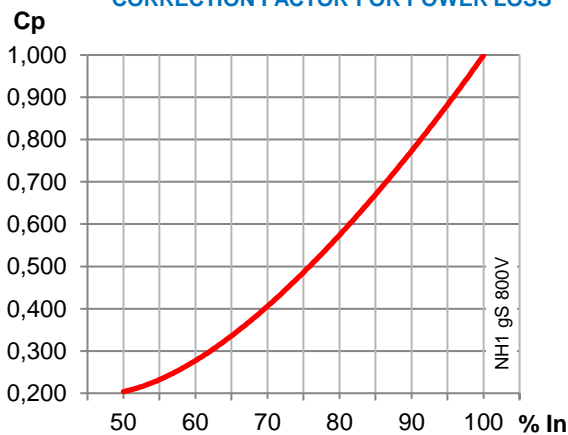

**$U_L$  (V)**  
*PEAK ARC VOLTAGE*

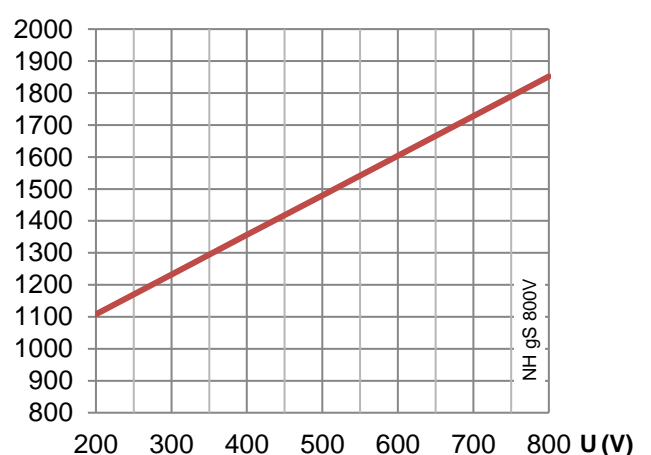

CARACTERÍSTICAS TÉCNICAS

TECHNICAL CHARACTERISTICS

CARACTERÍSTICAS TIEMPO-CORRIENTE  
TIME-CURRENT CHARACTERISTICS

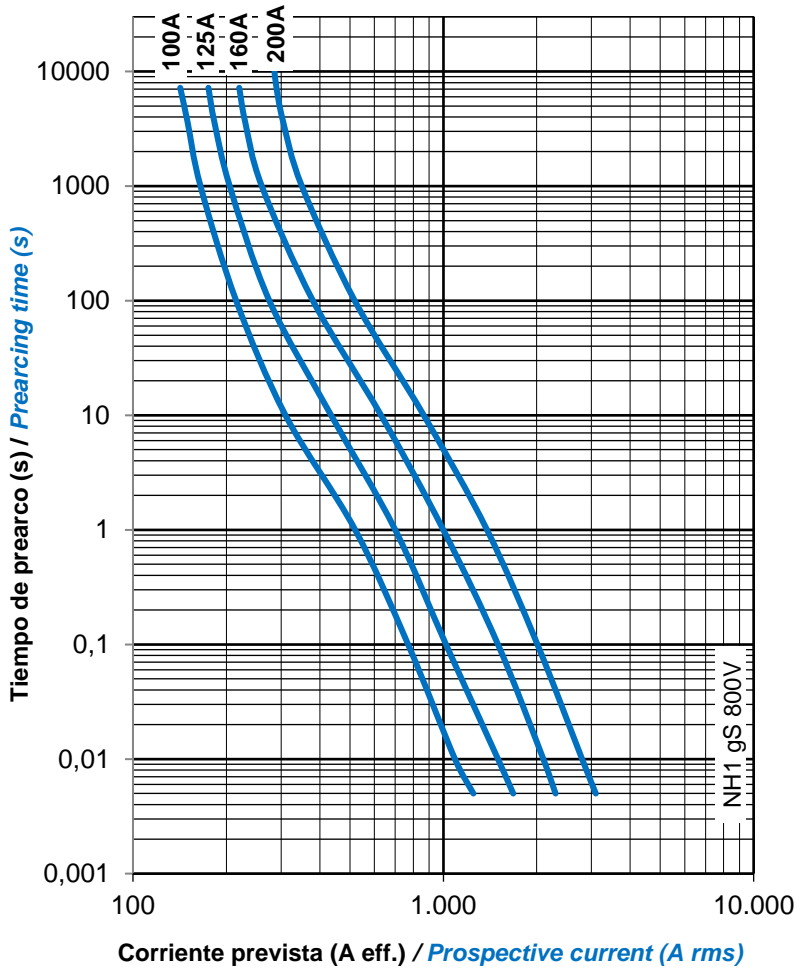

CARACTERÍSTICAS DE LIMITACIÓN  
CUT-OFF CHARACTERISTICS

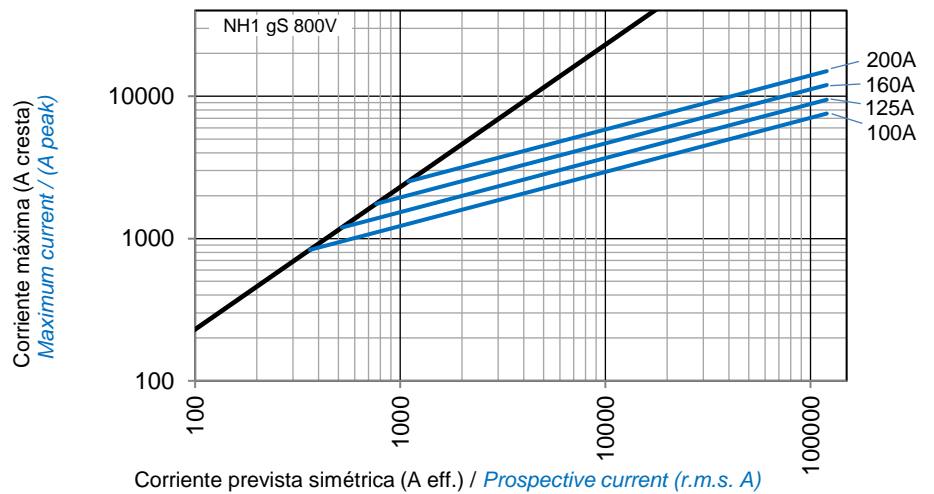

## CARACTERÍSTICAS TÉCNICAS

## TECHNICAL CHARACTERISTICS

Tamaño <i>Size:</i>	<b>NH3</b>
Clase <i>Class:</i>	<b>gS</b>
Tensión asignada <i>Rated voltage:</i>	<b>800 V ~</b>
Poder de corte asignado: <i>Rated breaking capacity:</i>	<b>120 kA</b>

	$I^2t$ prearco	$I^2t$ total @ 800V	Potencia disipada 0,8·In	Potencia disipada In
In	<i>Prearcing <math>I^2t</math></i>	<i>Operating <math>I^2t</math> @ 800V</i>	<i>Power loss 0,8·In</i>	<i>Power loss In</i>
(A)	(A <sup>2</sup> s)	(A <sup>2</sup> s)	(W)	(W)
<b>250</b>	30.300	98.000	16,2	27,5
<b>315</b>	58.200	187.000	19,5	33,0
<b>355</b>	86.900	279.000	19,9	33,7
<b>400</b>	121.300	390.000	22,1	37,5

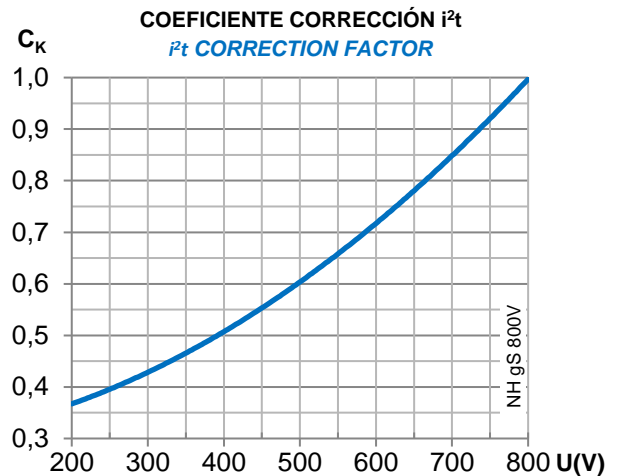

**COEFICIENTE CORRECCIÓN DE LA POTENCIA DISIPADA**  
**CORRECTION FACTOR FOR POWER LOSS**

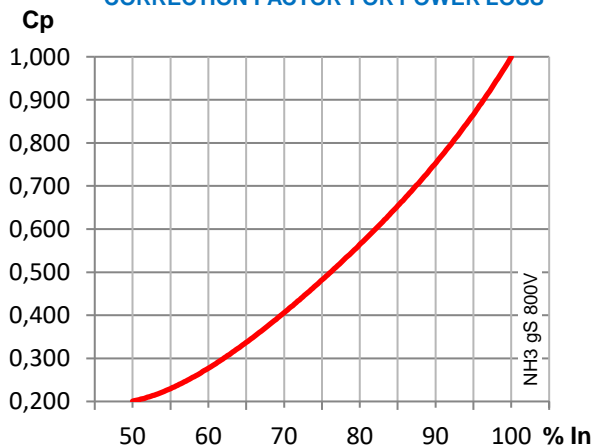

**TENSIÓN DE ARCO**  
**PEAK ARC VOLTAGE**

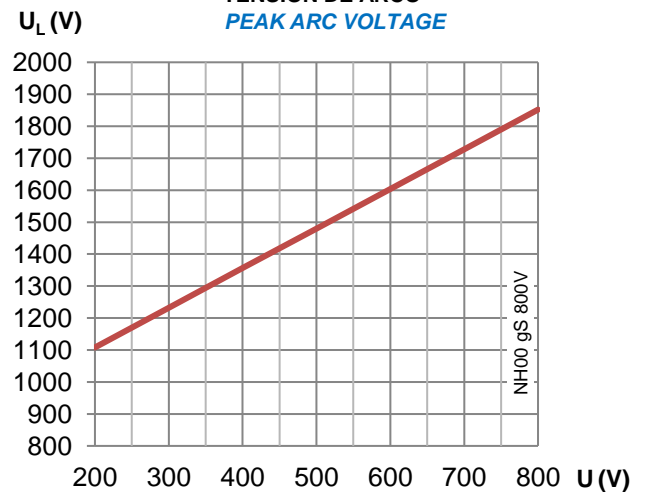

CARACTERÍSTICAS TÉCNICAS

TECHNICAL CHARACTERISTICS

CARACTERÍSTICAS TIEMPO-CORRIENTE  
TIME-CURRENT CHARACTERISTICS

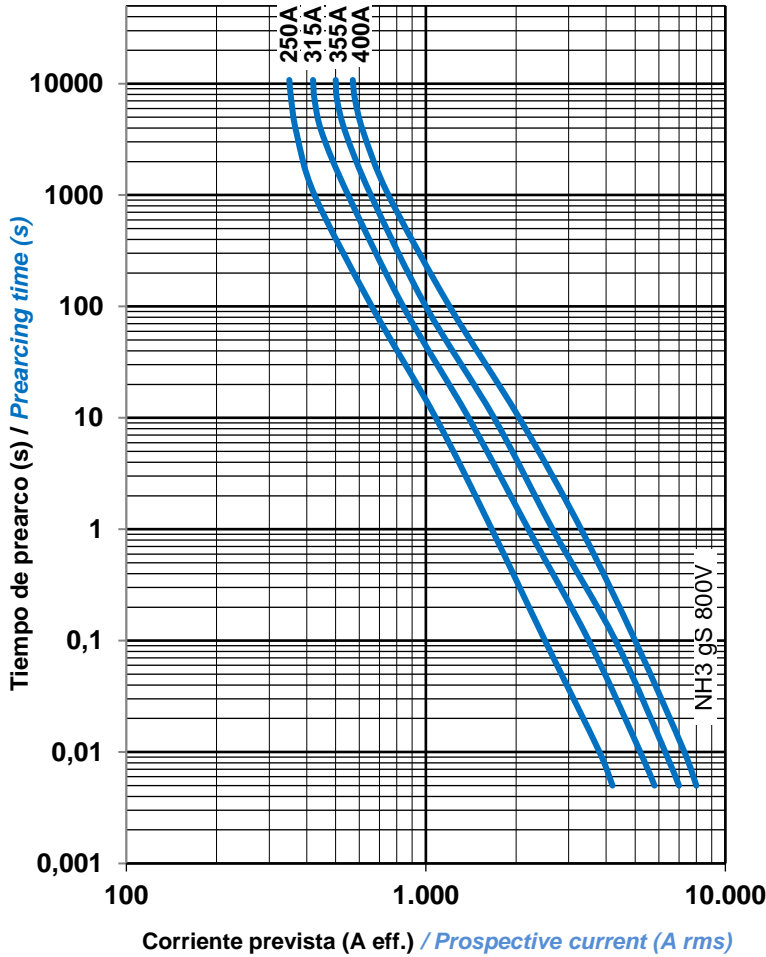

CARACTERÍSTICAS DE LIMITACIÓN  
CUT-OFF CHARACTERISTICS

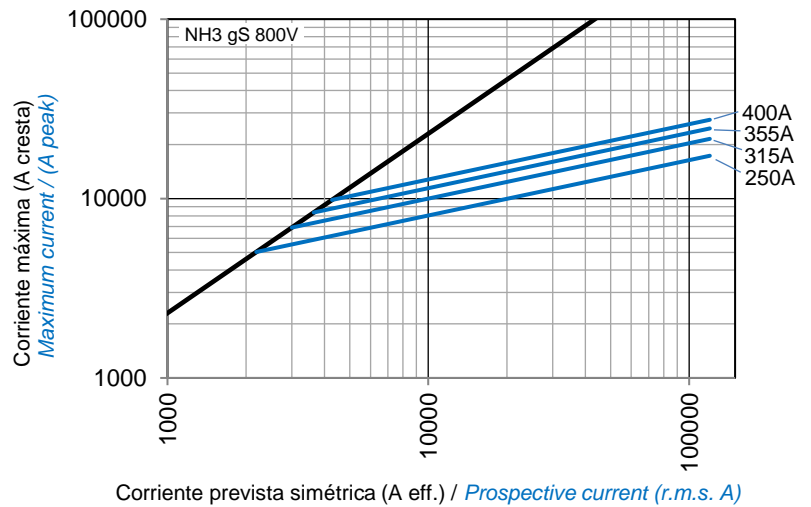

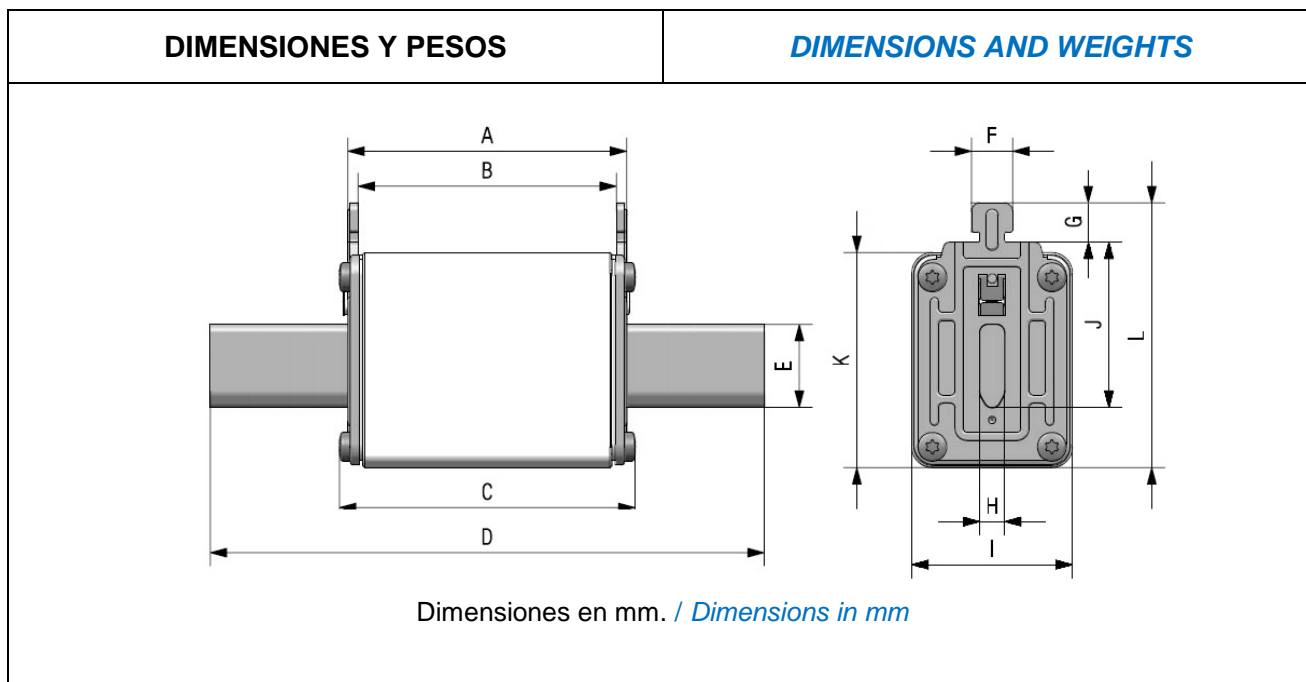

Tamaño <i>Size</i>	A	B	C	D	E	F	G	H	I	J	K	L	Peso <i>Weight</i>
<b>NH00</b>	49	44	52	78,5	15	10	9,5	6	29	35	47	59	0,18 kg
<b>NH1</b>	68	62	71,5	135	20	10	9,5	6	39	40	52	64	0,38 kg
<b>NH3</b>	68	62	73	150	32	10	9,5	6	70	60	75	87	1,02 kg

<b>MATERIALES</b>	
Cuerpo	Cerámica - Esteatita C221
Cuchillas	Cobre o latón plateado
Placas	Aluminio
Tornillería	Acero cincado

<i><b>MATERIALS</b></i>	
<i>Body</i>	<i>Ceramic - Steatite C221</i>
<i>Contact blades</i>	<i>Silver plated copper or brass</i>
<i>Plates</i>	<i>Aluminium</i>
<i>Screws</i>	<i>Zinc plated steel</i>