

**FUSIBLES NH XL PARA INSTALACIONES FOTOVOLTAICAS**  
**NH XL FUSE-LINKS FOR PHOTOVOLTAIC INSTALLATIONS**

**HORUS**<sup>®</sup>  
PHOTOVOLTAIC  
PROTECTION













**gPV 1500 VDC**





























**FICHA TÉCNICA / TECHNICAL DATA SHEET**



**DF ELECTRIC, S.A**  
C/. Silici, 67-69  
08940 CORNELLA DEL LLOBREGAT  
BARCELONA (SPAIN)  
[www.dfelectric.es](http://www.dfelectric.es)  
Telf.: +34-93 377 85 85  
Fax: +34-93 377 82 82

<ul style="list-style-type: none"> <li>● Los datos reflejados en esta ficha técnica están sujetos a la correcta instalación del producto de acuerdo con las instrucciones del fabricante, normas y reglamentos de instalación y conforme a las reglas profesionales, debidamente mantenidos y utilizados en las aplicaciones para las que está previsto.</li> <li>● Los productos descritos en este documento han sido diseñados, desarrollados y ensayados de acuerdo a una normativa específica. Se consideran componentes que son integrados formando parte de una instalación, máquina o equipo. La garantía y responsabilidad del correcto funcionamiento general del conjunto corresponde al fabricante de la instalación, máquina o equipo. DF Electric S.A. no puede garantizar las características de una instalación, máquina o equipo que ha sido diseñado por un tercero. Una vez que se ha seleccionado un producto, el usuario debe comprobar que es apropiado para su aplicación, mediante las verificaciones y/o ensayos que considere oportunos.</li> <li>● DF ELECTRIC se reserva el derecho a cambiar las dimensiones, especificaciones, materiales o el diseño de sus productos en cualquier momento con o sin previo aviso.</li> </ul>	<ul style="list-style-type: none"> <li>● <i>The data reflected in this technical record are subject to the correct installation of the product in accordance with manufacturer's instructions, relevant installation standards and professional practices, maintained and used in applications for which they were made.</i></li> <li>● <i>The products described in this document have been designed, developed and tested in accordance with specific standard. They are considered components that are integrated as part of installation, machine or equipment. The correct general operation of the referred product is responsibility of the manufacturer of the installation, machine or equipment. DF Electric S.A. cannot guarantee the characteristics of an installation, machine or equipment that has been designed by a third party. Once a product has been selected, the user must verify that it is appropriate for its application, through the verifications and/or tests that it deems appropriate.</i></li> <li>● <i>DF ELECTRIC retains the right to change the dimensions, specifications, materials or design of its products at any time with or without notice.</i></li> </ul>
 <p>De acuerdo a la directiva de residuos de aparatos eléctricos y electrónicos (WEEE) el material eléctrico no debe formar parte de los residuos habituales. Este símbolo alerta a los usuarios de que estos productos deben reciclarse según la normativa local medioambiental de eliminación de residuos.</p>	 <p><i>According to the waste of electrical and electronic equipment directive, electrical material should not be part of the usual waste. This symbol alerts users that these products should be recycled according to local environmental waste disposal regulations.</i></p>
 <p>El logotipo “<i>experto electrotécnico</i>” marcado sobre los productos incluidos en la presente ficha técnica indica que la instalación de estos productos debe ser realizada por personal experto con conocimientos especializados.</p>	 <p><i>The “electro technical expert” logo marked on the products included in this data sheet indicates that the installation of these products must be carried out by expert personnel with specialized knowledge.</i></p>
 <p>Para evitar riesgo eléctrico, realice la instalación sin tensión.</p>	 <p><i>To prevent electrical hazards, carry out the installation without voltage.</i></p>
 <p><a href="#">Advertencias de seguridad</a></p>	 <p><a href="#">Safety notice</a></p>

<b><u>DESCRIPCIÓN DEL PRODUCTO</u></b>	<b><u>PRODUCT DESCRIPTION</u></b>
<p>Los cartuchos fusibles de cuchilla <b>NH XL gPV 1500 V DC</b> para instalaciones fotovoltaicas de <b>DF Electric</b> han sido desarrollados para ofrecer una solución de protección, en agrupaciones de módulos (<i>arrays/subarrays</i>) o en la entrada DC de los inversores.</p> <p>La gama comprende cartuchos fusibles de tallas NH1XL, NH2XL y NH3L con corrientes asignadas comprendidas entre 40A y 500A</p> <p>La tensión asignada es de 1500 V DC.</p> <p>Disponibles en dos versiones de contacto, con cuchilla para montar en bases y versión para atornillar directamente sobre pletinas. En la versión con contacto cuchilla se puede montar un microrruptor sobre el indicador de fusión que permite monitorizar el estado del fusible.</p> <p>En la talla NH3L existe también una versión para atornillar directamente sobre pletinas que dispone de percutor, sobre el que se monta un microrruptor que permite monitorizar el estado del fusible.</p> <p>Proporcionan protección contra sobrecargas y cortocircuitos (clase gPV de acuerdo a las Normas IEC60269-6 y UL248-19), con una corriente mínima de fusión de <math>1,35 \cdot I_n</math>.</p> <p>Están contruidos con cuerpo de cerámica de alta resistencia a la presión interna y a los choques térmicos.</p> <p>Los contactos están realizados en cobre o latón plateado y los elementos de fusión son de plata, lo que evita el envejecimiento y mantiene inalterables las características.</p> <p>Tienen bajos valores de potencia disipada para una mejor eficiencia.</p> <p>UL Listed (File E355019) </p>	<p><i>NH gPV 1500 VDC fuse-links for photovoltaic installations from DF Electric have been developed to offer a safety protection solution in sub-array, array or at the DC input of inverters.</i></p> <p><i>The range comprises NH1XL, NH2XL and NH3L fuse-links with rated currents between 40A and 500A.</i></p> <p><i>Rated voltage is 1500 V DC.</i></p> <p><i>There are two versions of contacts, knife type to use in fuse-bases and bolted version to mount directly on busbar. In the knife version it is possible to mount a microswitch on the top indicator which allows the status of the fuse to be monitored.</i></p> <p><i>In size NH3L there is also a bolted version to mount directly on busbar, that has a striker on which the microswitch is mounted, which allows the status of the fuse to be monitored.</i></p> <p><i>They provide protection against overloads as well as short-circuits (gPV class according to IEC60269 and UL248-19 Standards, with a minimum fusing current of <math>1,35 \cdot I_n</math>.</i></p> <p><i>Made with ceramic body with high withstand to internal pressure and thermal shock.</i></p> <p><i>Contacts are made in silver plated copper or brass and melting elements are made in pure silver in order to avoid the aging and thus keep unalterable the electric characteristics.</i></p> <p><i>They have a low power losses values to get a good efficiency.</i></p> <p>UL Listed (File E355019) </p>
<b><u>NORMAS</u></b>	<b><u>STANDARDS</u></b>
IEC60269-1 (Fusibles – requisitos generales) IEC60269-6 (Fusibles para sistemas fotovoltaicos) UL248-1 (Fusibles – requisitos generales) UL248-19 (Fusibles fotovoltaica) Directiva RoHS	<i>IEC60269-1 (Fuse-links – general requirements)</i> <i>IEC60269-6 (Fuse-links for solar photovoltaic systems)</i> <i>UL248-1 (Fuse-links – general requirements)</i> <i>UL248-19 (Photovoltaic fuses)</i> <i>RoHS directive</i>

<b>GAMA</b>		<b>RANGE</b>		
TALLA	CORRIENTE ASIGNADA (A)	REFERENCIA CONTACTO CUCHILLA	REFERENCIA CONTACTO PARA ATORNILLAR	EMBALAJE
SIZE	RATED CURRENT (A)	REFERENCE KNIFE CONTACT	REFERENCE BOLTED CONTACT	PACKAGING
<b>NH1 XL</b>	40	372225 	372225B 	1
	50	372230 	372230B 	
	63	372235 	372235B 	
	80	372240 	372240B 	
	100	372245 	372245B 	
	125	372250 	372250B 	
	160	372255 	372255B 	
	200	372260 	372260B 	
<b>NH2 XL</b>	200	372350 	372350B 	1
	250	372360 	372360B 	
<b>NH3 L</b>	315	372445 	372445B 	1
	350	372448 	372448B 	
	355	372450 	372450B 	
	400	372455 	372455B 	

Microswitch NH000...NH3 * (250V 5A)	357010
* Solo para la version de cuchilla. * Only for knife contact version	

TALLA	CORRIENTE ASIGNADA (A)	REFERENCIA CONTACTO PARA ATORNILLAR + PERCUTOR	EMBALAJE
SIZE	RATED CURRENT (A)	REFERENCE BOLTED BLADE WITH STRIKER	PACKAGING
<b>NH3 L</b>	160	372420P	1
	200	372425P	
	250	372435P	
	315	372445P	
	355	372450P	
	400	372455P	
	450	372463P	
	500	372465P	

Microswitch (250V 4A)	357020
Para la version atornillar + percutor For bolted with striker version	



**CARACTERÍSTICAS TÉCNICAS**

**TECHNICAL CHARACTERISTICS**

<b>Tamaños</b> <i>Sizes</i>	NH1XL – NH2XL - NH3L	
<b>Tensión asignada</b> <i>Rated voltage</i>	1500V DC	
<b>Corrientes asignadas</b> <i>Rated currents</i>	40A...200A (NH1XL) 200A...250A (NH2XL) 315A...400A (NH3L) 160A...500A (NH3L percutor / <i>striker</i> )	
<b>Poder de corte asignado</b> <i>Rated breaking capacity</i>	Versión cuchilla y atornillado: <i>Knife and bolted versions:</i>	30 kA (L/R = 3 ms)
	NH3L Versión atornillado con percutor: <i>NH3L bolted with striker version:</i>	50 kA (L/R = 3 ms)
<b>Clase</b> <i>Class</i>	<b>gPV</b> (protección de sobrecargas y cortocircuitos) <i>(protection against overload and short-circuit)</i>	
<b>Corriente mínima de interrupción</b> <i>Minimum interrupt rating</i>	1,35·In	
<b>Corriente de no fusión</b> <i>Non fusing current</i>	1,13·In	
<b>Temperatura de almacenaje</b> <i>Storage temperature</i>	-40°C ... 90°C	
<b>Temperatura de funcionamiento</b> <i>Operating temperature</i>	-40°C ... 80°C *	

\* Para temperaturas ambiente superiores a 25°C es necesario aplicar un coeficiente de corrección sobre la corriente máxima.

\* For ambient temperatures higher than 25°C it is necessary to apply a derating in maximum current.

t <sub>a</sub> (°C)	A <sub>1</sub>
25	1
30	0,98
35	0,95
40	0,92
45	0,90
50	0,87
55	0,85
60	0,82
65	0,79
70	0,76
75	0,72
80	0,69

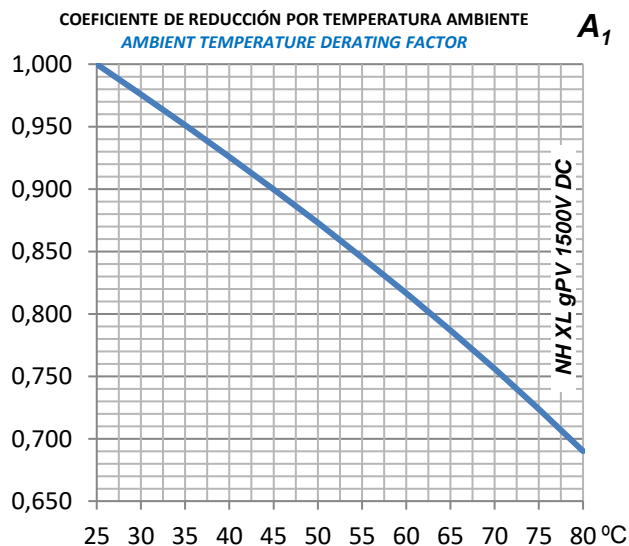

**CARACTERÍSTICAS TÉCNICAS**

**TECHNICAL CHARACTERISTICS**

VERSIONES CUCHILLA Y CONTACTO ATORNILLADO <i>KNIFE AND BOLTED VERSIONS</i>					
TALLA	CORRIENTE ASIGNADA (A)	POTENCIA DISIPADA (W) @ 0,7·In	POTENCIA DISIPADA (W) @ In	I <sup>2</sup> t PREARCO (A <sup>2</sup> s)	I <sup>2</sup> t TOTAL (A <sup>2</sup> s)
SIZE	RATED CURRENT (A)	POWER DISSIPATION (W) @ 0,7·In	POWER DISSIPATION (W) @ In	PREARcing I <sup>2</sup> t (A <sup>2</sup> s)	OPERATING I <sup>2</sup> t (A <sup>2</sup> s)
<b>NH1 XL</b>	40	6,3	15	260	490
	50	7,2	18	560	1.170
	63	7,6	19	1.160	2.460
	80	10	25	1.760	3.720
	100	10,4	26	3.970	8.380
	125	12	30	7.070	14.900
	160	15	38	13.360	28.180
<b>NH2 XL</b>	200	18	45	24.850	52.360
	250	21	52	42.000	88.500
<b>NH3 L</b>	315	25	61	114.000	172.080
	350	26	66	159.230	240.350
	355	27	68	159.230	240.350
	400	30	75	212.000	320.000

NH3L VERSIÓN CONTACTO ATORNILLADO CON PERCUTOR <i>NH3L BOLTED BLADE WITH STRIKER VERSION</i>					
TALLA	CORRIENTE ASIGNADA (A)	POTENCIA DISIPADA (W) @ 0,7·In	POTENCIA DISIPADA (W) @ In	I <sup>2</sup> t PREARCO (A <sup>2</sup> s)	I <sup>2</sup> t TOTAL (A <sup>2</sup> s)
SIZE	RATED CURRENT (A)	POWER DISSIPATION (W) @ 0,7·In	POWER DISSIPATION (W) @ In	PREARcing I <sup>2</sup> t (A <sup>2</sup> s)	OPERATING I <sup>2</sup> t (A <sup>2</sup> s)
<b>NH3 L</b>	160	14,0	36	17.800	40.700
	200	16,0	41	33.200	75.600
	250	18,8	48	59.000	134.500
	315	19,5	50	132.700	302.600
	355	22,0	56	180.600	411.800
	400	25,0	64	235.900	537.900
	450	26,5	66	361.300	823.800
	500	29,5	75	446.000	1.017.000

**CARACTERÍSTICAS TIEMPO-CORRIENTE**  
**(VERSIONES CUCHILLA Y CONTACTO ATORNILLADO)**

**TIME-CURRENT CHARACTERISTICS**  
**(KNIFE AND BOLTED VERSIONS)**

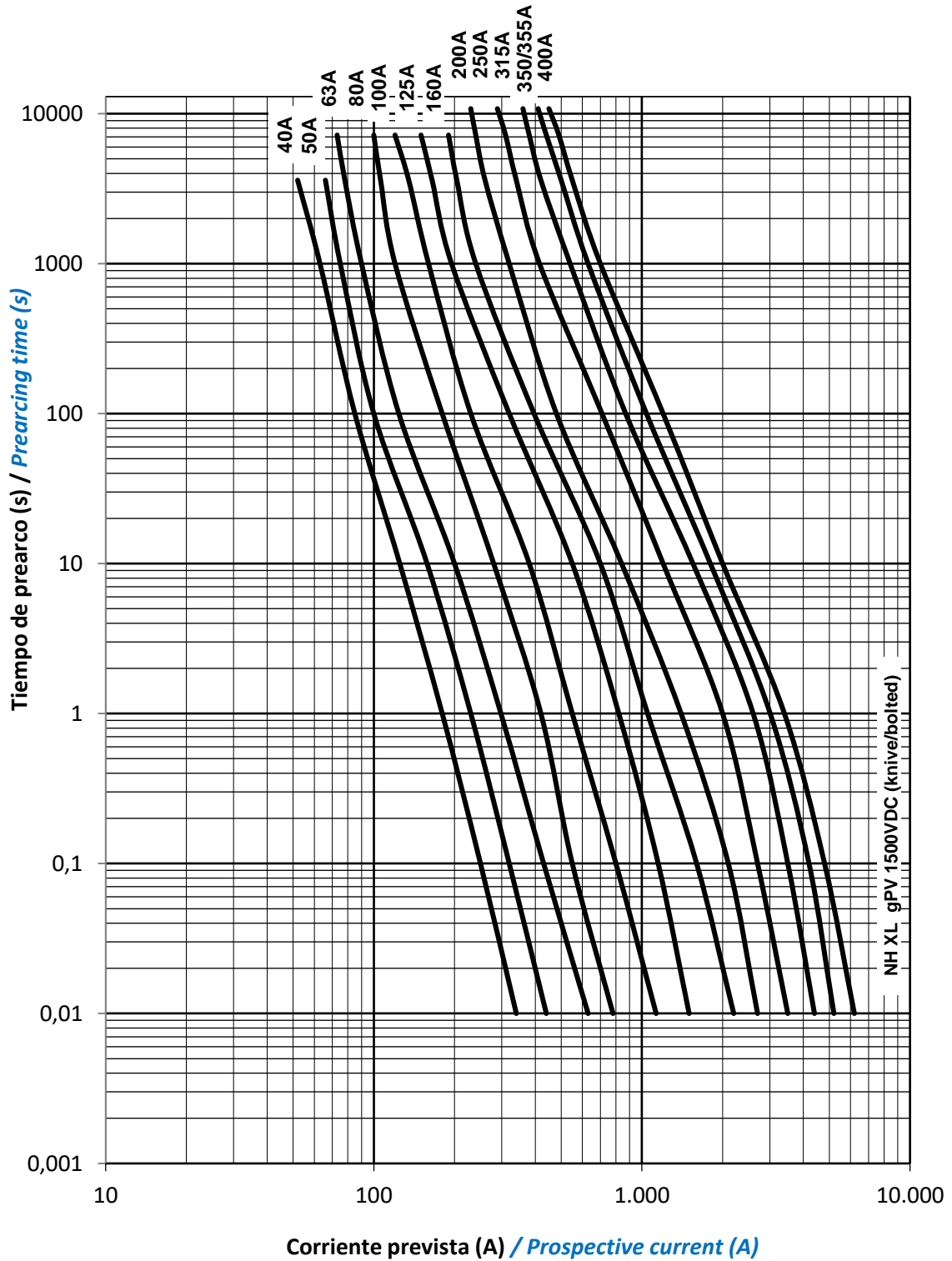

CARACTERÍSTICAS TIEMPO-CORRIENTE  
(VERSION CONTACTO ATORNILLADO CON PERCUTOR)

TIME-CURRENT CHARACTERISTICS  
(BOLTED BLADE WITH STRIKER VERSION)

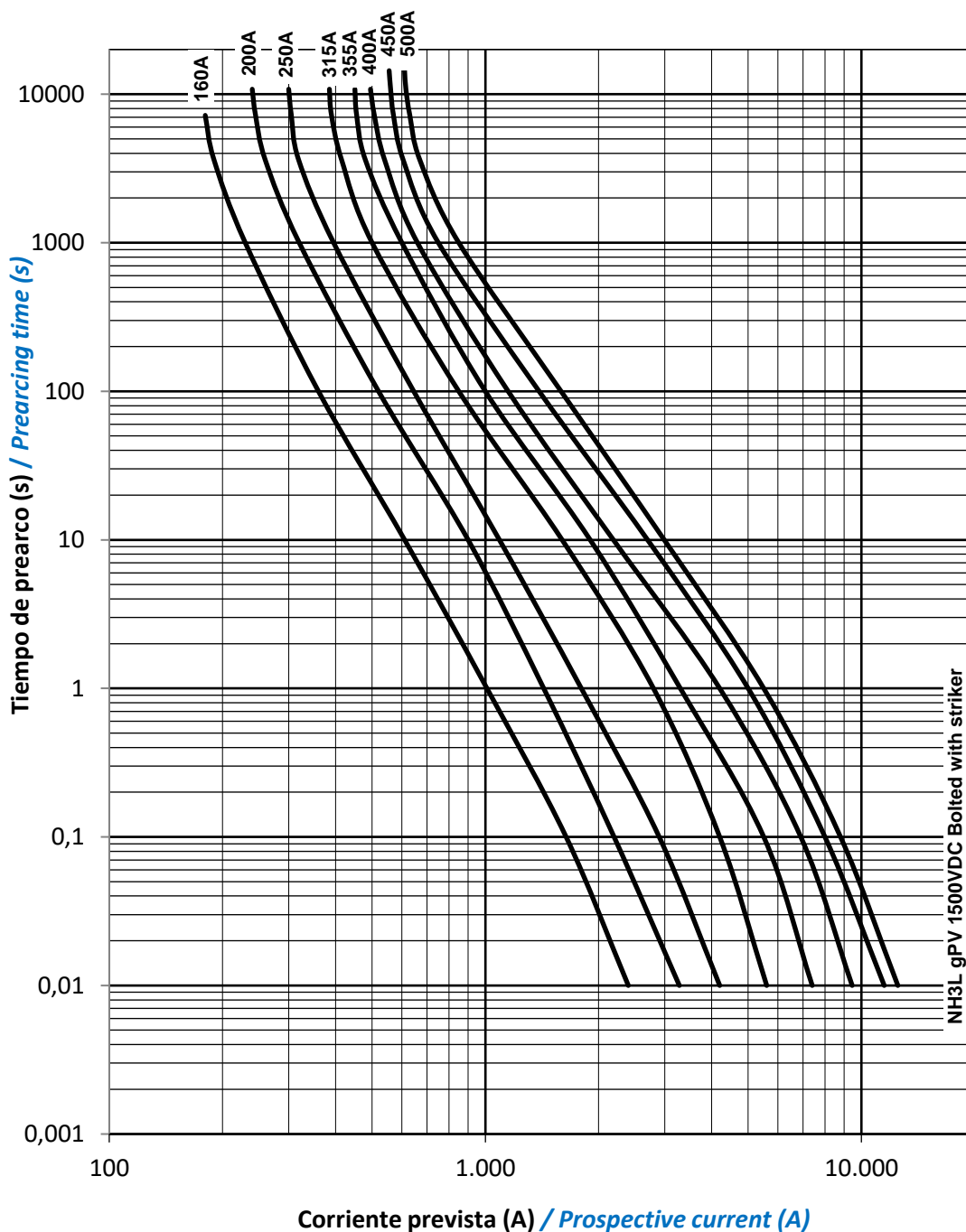

**DIMENSIONES (mm)**

**DIMENSIONS (mm)**

**CONTACTO CUCHILLA**  
**KNIFE CONTACT**

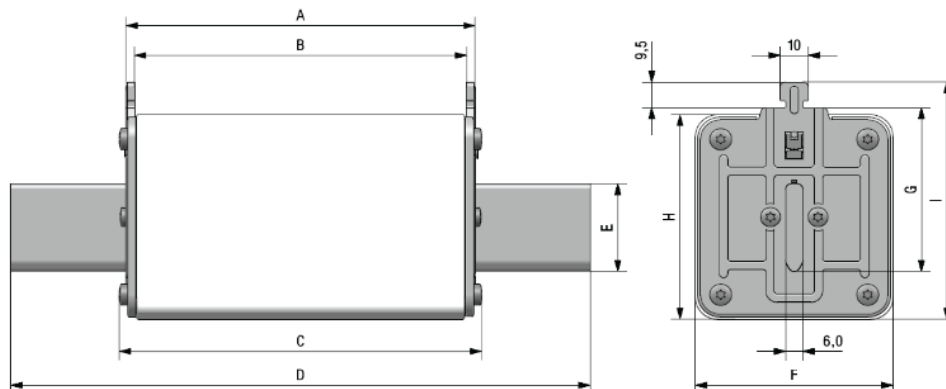

Talla / Size	A	B	C	D	E	F	G	H	I	Peso/weight
NH1 XL	126	120	129	191	20	39	40	52,5	64,5	0,65 kg
NH2 XL	122,6	117,6	126,7	205	25	53	48	60,5	72	0,99 kg
NH3 L	123,6	117,6	128,3	205	32	70	60	75	87	1,65 kg

**CONTACTO PARA ATORNILLAR**  
**BOLTED CONTACT**

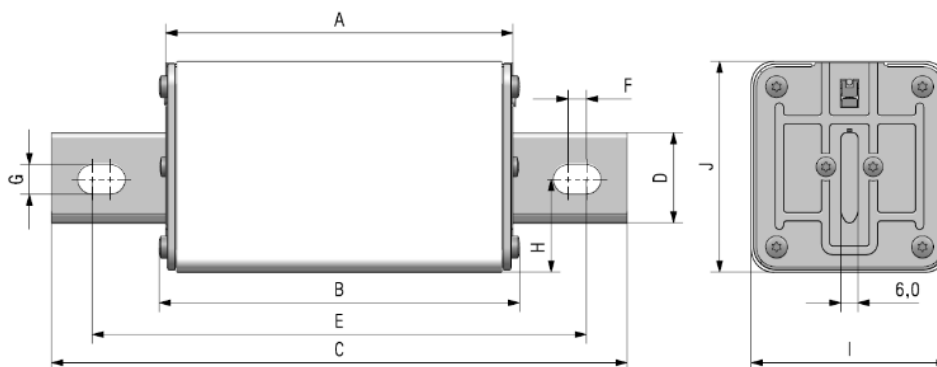

Talla / Size	A	B	C	D	E	F	G	H	I	J	Peso/weight
NH1 XL	126	129,0	191	20	170,5	9	8,5	25,6	39	52,5	0,64 kg
NH2 XL	122,6	126,7	205	25	173,0	9	10,5	27	53	60,5	0,98 kg
NH3 L	123,6	128,3	205	32	176,0	6,5	10,5	33	70	75,0	1,60 kg

Pares de apriete recomendados para los tornillos de conexión: NH1XL (M8): 10...12 Nm  
*Recommended torque for connection screws:* NH2XL-NH3L (M10): 30...35 Nm

Distancia mínima recomendada entre fusibles: 15 mm  
*Minimum recommended distance between fuse-links:*

**DIMENSIONES (mm)**

***DIMENSIONS (mm)***

**CONTACTO PARA ATORNILLAR CON PERCUTOR**  
***BOLTED BLADE WITH STRIKER***

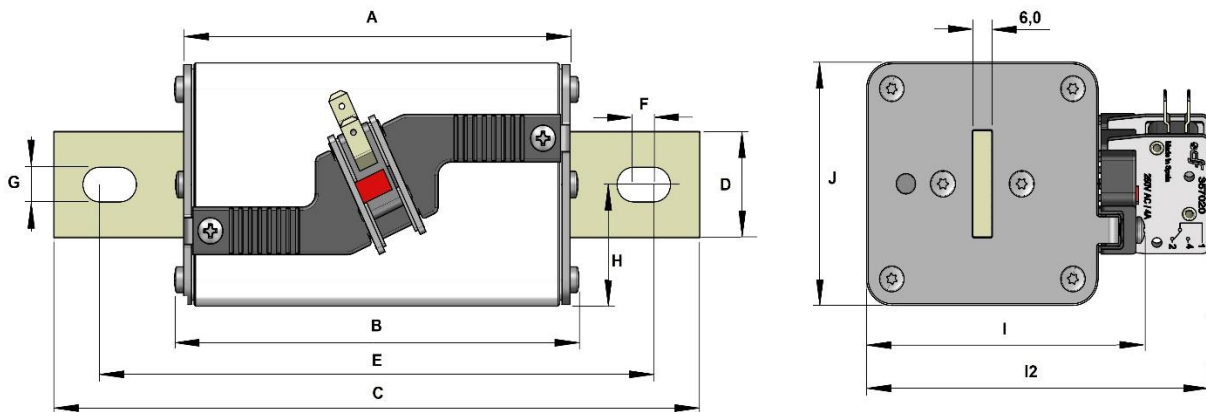

<i>Talla / Size</i>	<i>A</i>	<i>B</i>	<i>C</i>	<i>D</i>	<i>E</i>	<i>F</i>	<i>G</i>	<i>H</i>	<i>I</i>	<i>I2</i>	<i>J</i>	<i>Peso/weight</i>
<b>NH3 L</b>	122	127,7	205	32	176	6,5	10,5	36,5	88	108	73,5	1,86 kg

Pares de apriete recomendados para los tornillos de conexión:  
*Recommended torque for connection screws:*

NH3L (M10): 30...35 Nm

Distancia mínima recomendada entre fusibles:  
*Minimum recommended distance between fuse-links:*

15 mm

**MATERIALES**

Cuerpo	Cerámica
Cuchillas	Cobre o latón (plateadas o estañadas)
Placas	Aluminio o latón
Tornillería	Acero cincado

***MATERIALS***

<i>Body</i>	<i>Ceramics</i>
<i>Contact blades</i>	<i>Copper or brass (silver or tin plated)</i>
<i>Plates</i>	<i>Aluminium or brass</i>
<i>Screws</i>	<i>Zinc plated steel</i>

<b>GUÍA DE SELECCIÓN Y APLICACIÓN</b>	<b>SELECTION AND APPLICATION'S GUIDE</b>
<p>En las centrales fotovoltaicas, se dan unas condiciones de instalación y de funcionamiento que deben ser consideradas a la hora de seleccionar el fusible adecuado para la protección.</p> <p>Estos fusibles suelen ir montados en el interior de cajas estancas, donde se alcanzan temperaturas ambiente elevadas. Esto obliga a reducir la corriente máxima a través de los fusibles ya que en caso contrario podría producirse la fusión prematura de los mismos. Para evitarlo, se deben aplicar unos coeficientes de reducción.</p> <p>Por otro lado, los ciclos día/noche y el paso de nubes hacen que la corriente varíe continuamente a través de los fusibles, generando continuos calentamientos y enfriamientos que producen stress térmico y mecánico en los materiales, especialmente en el elemento de fusión. Para evitar un posible envejecimiento prematuro que provoca la fusión intempestiva, debemos aplicar un coeficiente de seguridad (DF Electric recomienda un valor de 0,80 para este tipo de aplicaciones).</p> <p>Teniendo presentes estas consideraciones, podemos seleccionar el fusible más adecuado.</p> <p>Para verificar que la tensión asignada del fusible es adecuada debemos tener en cuenta los siguientes puntos:</p> <ul style="list-style-type: none"> <li>• Tensión de circuito abierto de los módulos PV (<math>V_{oc}</math> STC)</li> <li>• Número de módulos conectados en serie (M).</li> <li>• Factor de seguridad (20%) para tener en cuenta el incremento de la tensión de vacío a temperaturas muy bajas.</li> </ul> <p>Así, la tensión asignada en DC mínima de los fusibles debe ser:</p> $V_{DC\text{Fusible}} \geq V_{oc}(\text{STC}) \cdot M \cdot 1,2$ <p>La tensión de circuito abierto de los módulos <math>V_{oc}</math> (STC) es la tensión máxima que un módulo fotovoltaico puede dar cuando funciona en vacío (sin ninguna carga conectada) en unas condiciones de ensayo determinadas (STC = <i>Standard Test Condition</i>) y es un dato indicado por el fabricante de los módulos fotovoltaicos.</p>	<p><i>In photovoltaic plants, there are a special installation and working conditions that must be considered to select the appropriate protection fuse-links.</i></p> <p><i>These fuses are usually placed inside plastic watertight boxes, where high ambient temperatures are reached. This condition force to reduce the maximum current that can circulate through the fuse-links, otherwise it would be have premature aging. To avoid non-desired operation of fuse-links it is necessary to apply a derating when select the appropriate rated current.</i></p> <p><i>On the other hand, the day/night cycles as well as the pass of clouds cause a constant current changes that generates continuous heating and cooling, and this cause a thermal stress in fuse-links materials, especially in the melting elements. To avoid premature aging another derating must be applied (DF Electric recommend a value of 0,80 for this application).</i></p> <p><i>With these considerations it is possible to select the suitable fuse.</i></p> <p><i>To verify that the rated voltage of fuse-link is sufficient, the following points must be taken into account:</i></p> <ul style="list-style-type: none"> <li>• <i>Open circuit voltage <math>V_{oc}</math> (STC) of PV modules.</i></li> <li>• <i>Numbers of modules connected in series (M).</i></li> <li>• <i>Safety factor (20%) to take into account the rise of open circuit voltage at very low temperatures.</i></li> </ul> <p><i>According to this, rated voltage in DC of fuse-links must be:</i></p> $V_{DC\text{Fusible}} \geq V_{oc}(\text{STC}) \cdot M \cdot 1,2$ <p><i>Open circuit voltage <math>V_{oc}</math> (STC) of PV modules is the maximum voltage that a Photovoltaic module can deliver when is working without load, measured under standard test conditions (STC). This information is given by the manufacturer of PV modules.</i></p>

Para escoger la corriente asignada del fusible a utilizar, los puntos a contemplar serán:

- Intensidad de cortocircuito de los módulos  $I_{SC}$  (STC)
- Número de *strings* conectados en paralelo ( $N_S$ )
- Factor de corrección de la temperatura ambiente ( $A_1$ ).
- Factor de corrección por variación de la corriente ( $A_2$ ).

La intensidad de cortocircuito de los módulos  $I_{SC}$  (STC) es la corriente máxima que un módulo fotovoltaico puede dar en unas condiciones de ensayo determinadas (STC) y es un dato indicado por el fabricante de los módulos fotovoltaicos.

Factor de corrección recomendado por variación de la corriente ( $A_2$ ): 0,80.

La temperatura ambiente en el interior de las cajas donde se alojan las protecciones puede alcanzar fácilmente valores de 40°C ó 45°C (para climas tropicales hay que considerar valores más elevados). Se debe aplicar un factor de corrección ( $A_1$ ) en función de la temperatura ambiente (ver tabla o gráfico de la página 5).

Con las consideraciones anteriores, la corriente asignada del fusible debe ser:

$$I_{N \text{ fusible}} \geq \frac{I_{SC \text{ STC}}}{A_1 \cdot A_2} \cdot N_S$$

Como ejemplo, si consideramos una temperatura ambiente máxima de 45°C, el calibre a utilizar sería:

$$I_{N \text{ fusible}} \geq \frac{I_{SC \text{ STC}}}{0,90 \cdot 0,80} \cdot N_S$$

$$I_{N \text{ fusible}} \geq 1,40 \cdot I_{SC \text{ STC}} \cdot N_S$$

*To choose rated current of fuse-links, points to be taken into account are the following:*

- *Short circuit current of PV modules  $I_{SC}$  (STC).*
- *Number of strings in parallel ( $N_S$ )*
- *Derating factor for ambient temperature ( $A_1$ ).*
- *Derating factor for current variation ( $A_2$ ).*

*Short circuit current of PV modules  $I_{SC \text{ STC}}$  is the maximum current that one module can deliver measured under standard test conditions (STC). This data is also given by the manufacturer of PV modules.*

*Recommended derating factor for current variation ( $A_2$ ): 0,80.*

*Ambient temperature inside boxes where are placed protections can reach easily 40°C or 45°C (for tropical countries it is necessary to consider higher values).*

*It should be applied a derating factor ( $A_1$ ) as function of ambient temperature (see table or graphic in pag. 5).*

*With previous considerations, rated current of fuse-link should be:*

$$I_{N \text{ fuse\_link}} \geq \frac{I_{SC \text{ STC}}}{A_1 \cdot A_2} \cdot N_S$$

*For example, if we consider a maximum ambient temperature of 45°C, the rating to use would be:*

$$I_{N \text{ fuse\_link}} \geq \frac{I_{SC \text{ STC}}}{0,90 \cdot 0,80} \cdot N_S$$

$$I_{N \text{ fuse\_link}} \geq 1,40 \cdot I_{SC \text{ STC}} \cdot N_S$$