

FUSIBLES NH XL PARA INSTALACIONES FOTOVOLTAICAS
NH XL FUSE-LINKS FOR PHOTOVOLTAIC INSTALLATIONS

HORUS[®]
PHOTOVOLTAIC
PROTECTION













gPV 1500 VDC

FICHA TÉCNICA / TECHNICAL DATA SHEET





























DF ELECTRIC, S.A
C/. Silici, 67-69
08940 CORNELLA DEL LLOBREGAT
BARCELONA (SPAIN)
www.dfelectric.es
Telf.: +34-93 377 85 85
Fax: +34-93 377 82 82

<ul style="list-style-type: none"> ● Los datos reflejados en esta ficha técnica están sujetos a la correcta instalación del producto de acuerdo con las instrucciones del fabricante, normas y reglamentos de instalación y conforme a las reglas profesionales, debidamente mantenidos y utilizados en las aplicaciones para las que está previsto. ● Los productos descritos en este documento han sido diseñados, desarrollados y ensayados de acuerdo a una normativa específica. Se consideran componentes que son integrados formando parte de una instalación, máquina o equipo. La garantía y responsabilidad del correcto funcionamiento general del conjunto corresponde al fabricante de la instalación, máquina o equipo. DF Electric S.A. no puede garantizar las características de una instalación, máquina o equipo que ha sido diseñado por un tercero. Una vez que se ha seleccionado un producto, el usuario debe comprobar que es apropiado para su aplicación, mediante las verificaciones y/o ensayos que considere oportunos. ● DF ELECTRIC se reserva el derecho a cambiar las dimensiones, especificaciones, materiales o el diseño de sus productos en cualquier momento con o sin previo aviso. 	<ul style="list-style-type: none"> ● <i>The data reflected in this technical record are subject to the correct installation of the product in accordance with manufacturer's instructions, relevant installation standards and professional practices, maintained and used in applications for which they were made.</i> ● <i>The products described in this document have been designed, developed and tested in accordance with specific standard. They are considered components that are integrated as part of installation, machine or equipment. The correct general operation of the referred product is responsibility of the manufacturer of the installation, machine or equipment. DF Electric S.A. cannot guarantee the characteristics of an installation, machine or equipment that has been designed by a third party. Once a product has been selected, the user must verify that it is appropriate for its application, through the verifications and/or tests that it deems appropriate.</i> ● <i>DF ELECTRIC retains the right to change the dimensions, specifications, materials or design of its products at any time with or without notice.</i>
 <p>De acuerdo a la directiva de residuos de aparatos eléctricos y electrónicos (WEEE) el material eléctrico no debe formar parte de los residuos habituales. Este símbolo alerta a los usuarios de que estos productos deben reciclarse según la normativa local medioambiental de eliminación de residuos.</p>	 <p><i>According to the waste of electrical and electronic equipment directive (WEEE), electrical material should not be part of the usual waste. This symbol alerts users that these products should be recycled according to local environmental waste disposal regulations.</i></p>
 <p>El logotipo “<i>experto electrotécnico</i>” marcado sobre los productos incluidos en la presente ficha técnica indica que la instalación de estos productos debe ser realizada por personal experto con conocimientos especializados.</p>	 <p><i>The “electro technical expert” logo marked on the products included in this data sheet indicates that the installation of these products must be carried out by expert personnel with specialized knowledge.</i></p>
 <p>Para evitar riesgo eléctrico, realice la instalación sin tensión.</p>	 <p><i>To prevent electrical hazards, carry out the installation without voltage.</i></p>
 <p>Advertencias de seguridad</p>	 <p>Safety notice</p>

<u>DESCRIPCIÓN DEL PRODUCTO</u>	<u>PRODUCT DESCRIPTION</u>
<p>Los cartuchos fusibles de cuchilla NH XL gPV 1500 V DC para instalaciones fotovoltaicas de DF Electric han sido desarrollados para ofrecer una solución de protección, en agrupaciones de módulos (<i>arrays/subarrays</i>) o en la entrada DC de los inversores.</p> <p>La gama comprende cartuchos fusibles de tallas NH1XL, NH2XL y NH3L con corrientes asignadas comprendidas entre 40A y 400A</p> <p>La tensión asignada es de 1500 V DC.</p> <p>Disponibles en dos versiones de contacto, con cuchilla para montar en bases y versión para atornillar directamente sobre pletinas. En la versión con contacto cuchilla se puede montar un microinterruptor sobre el indicador de fusión que permite monitorizar el estado del fusible.</p> <p>Proporcionan protección contra sobrecargas y cortocircuitos (clase gPV de acuerdo a las Normas IEC60269-6 y UL248-19), con una corriente mínima de fusión de $1,35 \cdot I_n$.</p> <p>Están contruidos con cuerpo de cerámica de alta resistencia a la presión interna y a los choques térmicos.</p> <p>Los contactos están realizados en cobre o latón plateado y los elementos de fusión son de plata, lo que evita el envejecimiento y mantiene inalterables las características.</p> <p>Tienen bajos valores de potencia disipada para una mejor eficiencia.</p> <p>UL Listed (File E355019) </p>	<p><i>NHXL gPV 1500 VDC fuse-links for photovoltaic installations from DF Electric have been developed to offer a safety protection solution in sub-array, array or at the DC input of inverters.</i></p> <p><i>The range comprises NH1XL, NH2XL and NH3L fuse-links with rated currents between 40A and 400A.</i></p> <p><i>Rated voltage is 1500 V DC.</i></p> <p><i>There are two versions of contacts, knife type to use in fuse-bases and bolted version to mount directly on busbar. In the knife version it is possible to mount a microswitch on the top indicator which allows the status of the fuse to be monitored.</i></p> <p><i>They provide protection against overloads as well as short-circuits (gPV class according to IEC60269 and UL248-19 Standards, with a minimum fusing current of $1,35 \cdot I_n$.</i></p> <p><i>Made with ceramic body with high withstand to internal pressure and thermal shock.</i></p> <p><i>Contacts are made in silver plated copper or brass and melting elements are made in pure silver in order to avoid the aging and thus keep unalterable the electric characteristics.</i></p> <p><i>They have a low power losses values to get a good efficiency.</i></p> <p>UL Listed (File E355019) </p>
<u>NORMAS</u>	<u>STANDARDS</u>
IEC60269-1 (Fusibles – requisitos generales) IEC60269-6 (Fusibles para sistemas fotovoltaicos) UL248-1 (Fusibles – requisitos generales) UL248-19 (Fusibles fotovoltaica) Directiva RoHS	<i>IEC60269-1 (Fuse-links – general requirements)</i> <i>IEC60269-6 (Fuse-links for solar photovoltaic systems)</i> <i>UL248-1 (Fuse-links – general requirements)</i> <i>UL248-19 (Photovoltaic fuses)</i> <i>RoHS directive</i>

GAMA

RANGE

TALLA	CORRIENTE ASIGNADA (A)	REFERENCIA CONTACTO CUCHILLA	REFERENCIA CONTACTO PARA ATORNILLAR	EMBALAJE
SIZE	RATED CURRENT (A)	REFERENCE KNIFE CONTACT	REFERENCE BOLTED CONTACT	PACKAGING
NH1 XL	40	372225 	372225B 	1
	50	372230 	372230B 	
	63	372235 	372235B 	
	80	372240 	372240B 	
	100	372245 	372245B 	
	125	372250 	372250B 	
	160	372255 	372255B 	
	200	372260	372260B	
NH2 XL	200	372350 	372350B 	1
	250	372360 	372360B 	
NH3 L	315	372445 	372445B 	1
	350	372448 	372448B 	
	355	372450 	372450B 	
	400	372455 	372455B 	

<p>Microswitch NH000...NH3 * (250V 5A)</p>	357010
<p>* Solo para la version de cuchilla. * Only for knife contact version</p>	



CARACTERÍSTICAS TÉCNICAS

TECHNICAL CHARACTERISTICS

Tamaños <i>Sizes</i>	NH1XL – NH2XL - NH3L	
Tensión asignada <i>Rated voltage</i>	1500V DC	
Corrientes asignadas <i>Rated currents</i>	40A...200A (NH1XL) 200A...250A (NH2XL) 315A...400A (NH3L)	
Poder de corte asignado <i>Rated breaking capacity</i> (L/R = 3 ms)	IEC	NH1XL 40A...160A → 100 kA NH1XL 200A → 30 kA NH2XL 200A - 250A → 100 kA NH3L 315A...400A → 100 kA
	UL	30 kA
Clase <i>Class</i>	gPV	(protección de sobrecargas y cortocircuitos) <i>(protection against overload and short-circuit)</i>
Corriente mínima de interrupción <i>Minimum interrupt rating</i>	1,35·In	
Corriente de no fusión <i>Non fusing current</i>	1,13·In	
Temperatura de almacenaje <i>Storage temperature</i>	-40°C ... 90°C	
Temperatura ambiente de funcionamiento <i>Ambient operating temperature</i>	-40°C ... 80°C *	

Para temperaturas ambiente superiores a 25°C es necesario aplicar un coeficiente de corrección sobre la corriente máxima.
* For ambient temperatures higher than 25°C it is necessary to apply a derating in maximum current.

t _a (°C)	A ₁
25	1
30	0,98
35	0,95
40	0,92
45	0,90
50	0,87
55	0,85
60	0,82
65	0,79
70	0,76
75	0,72
80	0,69

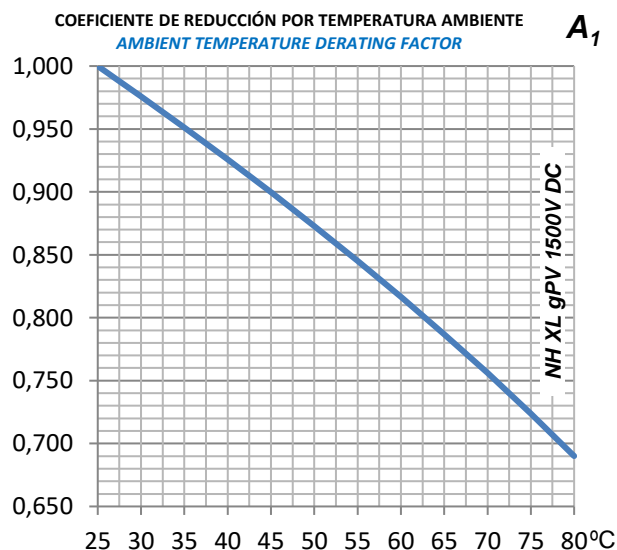

CARACTERÍSTICAS TÉCNICAS

TECHNICAL CHARACTERISTICS

VERSIONES CUCHILLA Y CONTACTO ATORNILLADO <i>KNIFE AND BOLTED VERSIONS</i>					
TALLA	CORRIENTE ASIGNADA (A)	POTENCIA DISIPADA (W) @ 0,7·In	POTENCIA DISIPADA (W) @ In	I ² t PREARCO (A ² s)	I ² t TOTAL (A ² s)
SIZE	RATED CURRENT (A)	POWER DISSIPATION (W) @ 0,7·In	POWER DISSIPATION (W) @ In	PREARCING I ² t (A ² s)	OPERATING I ² t (A ² s)
NH1 XL	40	6,3	15	260	490
	50	7,2	18	560	1.170
	63	7,6	19	1.160	2.460
	80	10	25	1.760	3.720
	100	10,4	26	3.970	8.380
	125	12	30	7.070	14.900
	160	15	38	13.360	28.180
NH2 XL	200	18	45	24.850	52.360
	250	21	52	42.000	88.500
NH3 L	315	25	61	114.000	172.080
	350	26	66	159.230	240.350
	355	27	68	159.230	240.350
	400	30	75	212.000	320.000

MATERIALES	
Cuerpo	Cerámica
Cuchillas	Cobre o latón (plateadas)
Placas	Aluminio
Tornillería	Acero cincado

MATERIALS	
<i>Body</i>	<i>Ceramics</i>
<i>Contact blades</i>	<i>Copper or brass (silver plated)</i>
<i>Plates</i>	<i>Aluminium</i>
<i>Screws</i>	<i>Zinc plated steel</i>

**CARACTERÍSTICAS TIEMPO-CORRIENTE
(VERSIONES CUCHILLA Y CONTACTO ATORNILLADO)**

**TIME-CURRENT CHARACTERISTICS
(KNIFE AND BOLTED VERSIONS)**

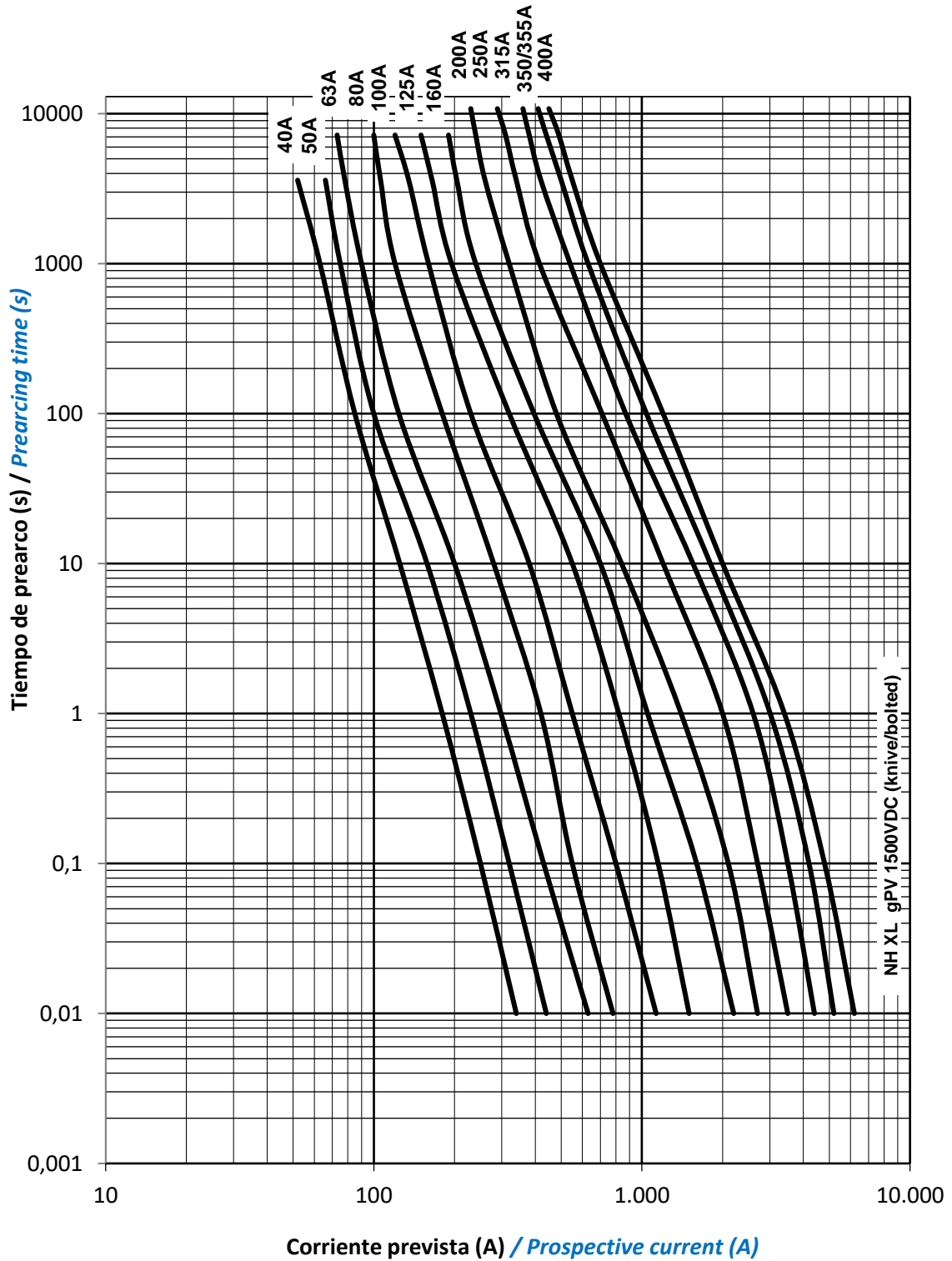

DIMENSIONES (mm)

DIMENSIONS (mm)

CONTACTO CUCHILLA
KNIFE CONTACT

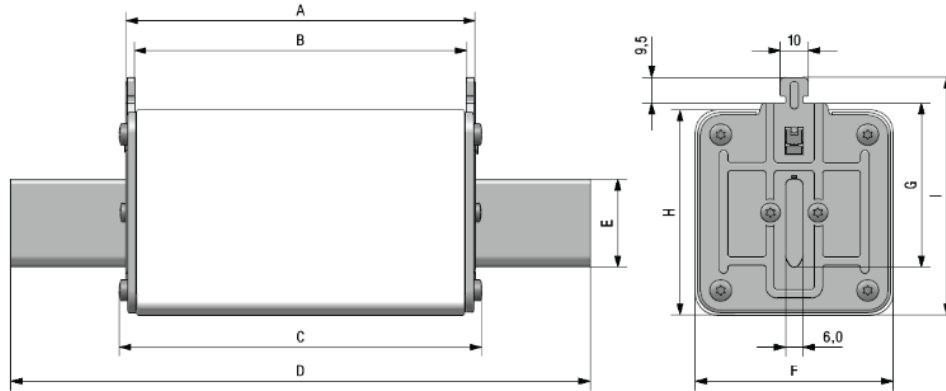

<i>Talla / Size</i>	<i>A</i>	<i>B</i>	<i>C</i>	<i>D</i>	<i>E</i>	<i>F</i>	<i>G</i>	<i>H</i>	<i>I</i>	<i>Peso/weight</i>
NH1 XL	126	120	129	191	20	39	40	52,5	64,5	0,65 kg
NH2 XL	122,6	117,6	126,7	205	25	53	48	60,5	72	0,99 kg
NH3 L	123,6	117,6	128,3	205	32	70	60	75	87	1,65 kg

CONTACTO PARA ATORNILLAR
BOLTED CONTACT

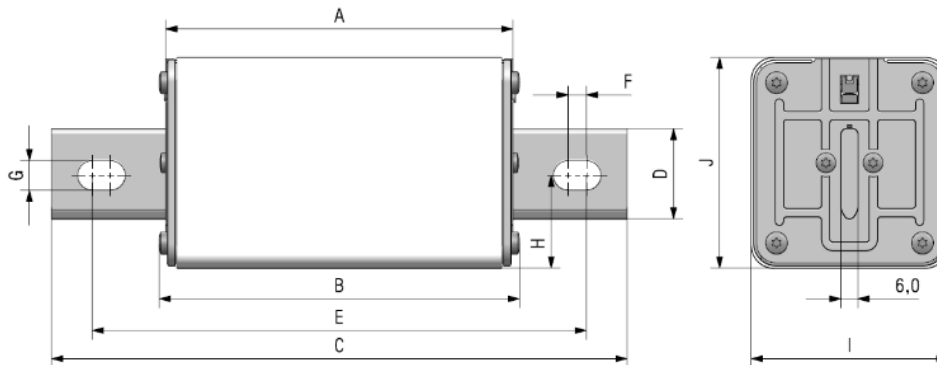

<i>Talla / Size</i>	<i>A</i>	<i>B</i>	<i>C</i>	<i>D</i>	<i>E</i>	<i>F</i>	<i>G</i>	<i>H</i>	<i>I</i>	<i>J</i>	<i>Peso/weight</i>
NH1 XL	126	129,0	191	20	170,5	9	8,5	25,6	39	52,5	0,64 kg
NH2 XL	122,6	126,7	205	25	173,0	9	10,5	27	53	60,5	0,98 kg
NH3 L	123,6	128,3	205	32	176,0	6,5	10,5	33	70	75,0	1,60 kg

Pares de apriete recomendados para los tornillos de conexión: **NH1XL (M8): 10...12 Nm**
Recommended torque for connection screws: **NH2XL-NH3L (M10): 30...35 Nm**

Distancia mínima recomendada entre fusibles: **15 mm**
Minimum recommended distance between fuse-links:

GUÍA DE SELECCIÓN Y APLICACIÓN	SELECTION AND APPLICATION'S GUIDE
<p>REQUISITOS PARA LA PROTECCIÓN CONTRA SOBRECORRIENTES DE AGRUPACIONES (SUB-ARRAY/ARRAY)</p> <p>Tensión asignada de los fusibles</p> <p>Para verificar que la tensión asignada del fusible es adecuada debemos tener en cuenta los siguientes puntos:</p> <ul style="list-style-type: none"> • Tensión de circuito abierto de los módulos PV (V_{OC} STC) • Número de módulos conectados en serie (M). • Factor de seguridad (20%) para tener en cuenta el incremento de la tensión de vacío a temperaturas muy bajas. <p>La tensión de circuito abierto de los módulos V_{OC} (STC) es la tensión máxima que un módulo fotovoltaico puede dar cuando funciona en vacío (sin ninguna carga conectada) en unas condiciones de ensayo determinadas (STC = <i>Standard Test Condition</i>) y es un dato indicado por el fabricante de los módulos fotovoltaicos.</p> <p>Así, la tensión asignada en DC mínima de los fusibles debe ser:</p> $V_{DC_fusible} \geq V_{OC} (STC) \cdot M \cdot 1,2$ <p>Se puede prescindir del factor de seguridad del 20% si se puede determinar con seguridad que bajo ninguna circunstancia la tensión de la instalación superará el valor de la tensión asignada de los fusibles.</p> <p>Corriente asignada de los fusibles</p> <p>De acuerdo a las recomendaciones de las Normas IEC 60364-7-712, IEC 62548 y IEC 60269-5, para escoger la corriente asignada del fusible a utilizar, los puntos a contemplar serán:</p> <ul style="list-style-type: none"> • Intensidad de cortocircuito de los módulos I_{sc} (STC) • Factor de corrección de la temperatura ambiente (A_1). • Número de <i>strings</i> que forman el grupo (<i>sub-array</i> o <i>array</i>) (N_s). 	<p>REQUIREMENTS FOR SUB-ARRAY OR ARRAY OVERCURRENT PROTECTION</p> <p>Rated voltage of fuse-links</p> <p><i>To verify that the rated voltage of fuse-link is sufficient, the following points must be taken into account:</i></p> <ul style="list-style-type: none"> • <i>Open circuit voltage (V_{OC} STC) of PV modules.</i> • <i>Numbers of modules connected in series (M).</i> • <i>Safety factor (20%) to take into account the rise of open circuit voltage at very low temperatures.</i> <p><i>Open circuit voltage V_{OC} STC of PV modules is the maximum voltage that a Photovoltaic module can deliver when is working without load, measured under standard test conditions (STC). This information is given by the manufacturer of PV modules.</i></p> <p><i>According to this, rated voltage in DC of fuse-links must be:</i></p> $V_{DC_fuse} \geq V_{OC} (STC) \cdot M \cdot 1,2$ <p><i>The 20% safety factor can be avoided with if it can be determined with certainty that under no circumstances the voltage of the installation won't exceed the value of the assigned voltage of the fuses.</i></p> <p>Rated current of fuse-links</p> <p><i>According to the recommendations of IEC 60364-7-712, IEC 62548 and IEC 60269-5 standards, the points to consider when selecting the nominal current of the fuse are:</i></p> <ul style="list-style-type: none"> • <i>Short circuit current of PV modules I_{sc} (STC).</i> • <i>Derating factor for ambient temperature (A_1).</i> • <i>Number of strings in the group (sub-array or array) (N_s).</i>

La intensidad de cortocircuito de los módulos I_{SC} (STC) es la corriente máxima que un módulo fotovoltaico puede dar en unas condiciones de ensayo determinadas (STC) y es un dato indicado por el fabricante de los módulos fotovoltaicos.

Para hallar la corriente de cortocircuito del grupo deberemos multiplicar el número de *strings* que forman en grupo (N_s) por la corriente de cortocircuito de los módulos I_{SC} (STC).

$$I_{SC_ARRAY} = N_s \cdot I_{SC_MOD}$$

Donde:

I_{SC_ARRAY} es la corriente de cortocircuito del grupo (*sub-array* o *array*).

N_s es el número de *strings* que forman el grupo.

I_{SC_MOD} es la corriente de cortocircuito de los módulos.

Se debe aplicar un factor de corrección (A_1) en función de la temperatura ambiente (ver tabla o gráfico de la página 5).

La corriente asignada del fusible debe ser:

$$1,25 \cdot I_{SC_ARRAY} < I_n \leq 2,4 \cdot I_{SC_ARRAY}$$

Para tener en cuenta el factor de corrección de la temperatura ambiente deberemos utilizar la siguiente expresión:

$$1,25 \cdot I_{SC_ARRAY} < (I_n \cdot A_1) \leq 2,4 \cdot I_{SC_ARRAY}$$

Donde:

I_{SC_ARRAY} es la corriente de cortocircuito del grupo de *strings* (*sub-array* o *array*).

I_n es la corriente asignada del fusible.

A_1 es el factor de corrección de la temperatura ambiente.

Short circuit current of PV modules I_{SC} (STC) is the maximum current that one module can deliver measured under standard test conditions (STC). This data is also given by the manufacturer of PV modules.

To find the short-circuit current of the group, we must multiply the number of strings that form the group (N_s) by the short-circuit current of the modules I_{SC} (STC).

$$I_{SC_ARRAY} = N_s \cdot I_{SC_MOD}$$

Where:

I_{SC_ARRAY} is the short-circuit current of group (sub-array or array).

N_s is the number of strings in the group.

I_{SC_MOD} is the short-circuit current of the modules.

It should be applied a derating factor (A_1) as function of ambient temperature (see table or graphic in pag. 5).

Rated current of fuse-link should be:

$$1,25 \cdot I_{SC_ARRAY} < I_n \leq 2,4 \cdot I_{SC_ARRAY}$$

To take into account the ambient temperature correction factor, we shall use the following expression:

$$1,25 \cdot I_{SC_ARRAY} < (I_n \cdot A_1) \leq 2,4 \cdot I_{SC_ARRAY}$$

Where:

I_{SC_ARRAY} is the short-circuit current of strings group (sub-array or array).

I_n is the rated current of fuse-link.

A_1 is the derating factor for ambient temperature.