

BASES INDUSTRIALES PARA
FUSIBLES CILÍNDRICOS

INDUSTRIAL FUSEHOLDERS
FOR CYLINDRICAL FUSELINKS

PMX-22



**PROTECTING
THE WORLD**



Oficina Central y Fábrica / Head Office

Silici, 67-69 08940 Cornellà de Llobregat -
Barcelona (SPAIN)

Tel. (+34) 93 377 85 85 - Fax. (+34) 93 377 82 82

info@dfelectric.es

www.dfelectric.es



PMX-22

BASES INDUSTRIALES PARA FUSIBLES CILÍNDRICOS
INDUSTRIAL FUSEHOLDERS FOR CYLINDRICAL FUSELINKS

Los datos reflejados en esta ficha técnica están sujetos a la correcta instalación del producto de acuerdo con las instrucciones del fabricante, normas y reglamentos de instalación y conforme a las reglas profesionales, debidamente mantenidos y utilizados en las aplicaciones para las que está previsto.

Los productos descritos en este documento han sido diseñados, desarrollados y ensayados de acuerdo a una normativa específica. Se consideran componentes que son integrados formando parte de una instalación, máquina o equipo.

La garantía y responsabilidad del correcto funcionamiento general del conjunto corresponde al fabricante de la instalación, máquina o equipo.

DF Electric S.A. no puede garantizar las características de una instalación, máquina o equipo que ha sido diseñado por un tercero. Una vez que se ha seleccionado un producto, el usuario debe comprobar que es apropiado para su aplicación, mediante las verificaciones y/o ensayos que considere oportunos.

DF ELECTRIC se reserva el derecho a cambiar las dimensiones, especificaciones, materiales o el diseño de sus productos en cualquier momento sin previo aviso.

The data reflected in this technical record are subject to the correct installation of the product in accordance with manufacturer's instructions, relevant installation standards and professional practices, maintained and used in applications for which they were made.

The products described in this document have been designed, developed and tested in accordance with specific standard. They are considered components that are integrated as part of installation, machine or equipment.

The correct general operation of the referred product is responsibility of the manufacturer of the installation, machine or equipment.

DF Electric SA cannot guarantee the characteristics of an installation, machine or equipment that has been designed by a third party. Once a product has been selected, the user must verify that it is appropriate for its application, through the verifications and/or tests that it deems appropriate.

DF ELECTRIC retains the right to change the dimensions, specifications, materials or design of its products at any time with or without notice.



De acuerdo a la directiva de residuos de aparatos eléctricos y electrónicos (WEEE) el material eléctrico no debe formar parte de los residuos habituales.

Este símbolo alerta a los usuarios de que estos productos deben reciclarse según la normativa local medioambiental de eliminación de residuos



According to the waste of electrical and electronic equipment directive, electrical material should not be part of the usual waste.

This symbol alerts users that these products should be recycled according to local environmental waste disposal regulations.



El logotipo "experto electrotécnico" marcado sobre los productos incluidos en la presente ficha técnica indica que la instalación de estos productos debe ser realizada por personal experto con conocimientos especializados.



The "electro technical expert" logo marked on the products included in this data sheet indicates that the installation of these products must be carried out by expert personnel with specialized knowledge.



Para evitar riesgo eléctrico, realice la instalación sin tensión.



To prevent electrical hazards, carry out the installation without voltage.



Advertencias de seguridad



Safety notice





PMX-22

BASES INDUSTRIALES PARA FUSIBLES CILÍNDRICOS
INDUSTRIAL FUSEHOLDERS FOR CYLINDRICAL FUSELINKS

DESCRIPCIÓN DEL PRODUCTO

- ▶ Bases portafusibles modulares para utilizar con fusibles cilíndricos talla 22x58 según norma IEC/EN 60269.
- ▶ Diseño compacto, de dimensiones reducidas.
- ▶ Zonas de ventilación optimizadas para una mejor disipación del calor.
- ▶ Fabricadas con materiales de calidad:
 - Contactos de cobre electrolítico plateados.
 - Materiales plásticos auto extingüibles y de alta resistencia a la temperatura.
 - Todos los materiales utilizados son conformes a la Directiva europea RoHS (Restricción de ciertas sustancias peligrosas en el material eléctrico) así como libres de halógenos.



- ▶ Amplia gama de diferentes versiones.
- ▶ Amplia gama de accesorios disponible.

PRODUCT DESCRIPTION

- ▶ Modular fuse holders for cylindrical fuse links size 22x58 according IEC/EN 60269 standard.
- ▶ Compact design, with reduced distances.
- ▶ Ventilation zones optimized for a better heat dissipation
- ▶ Manufactured with a high quality materials
 - Silver plated copper contacts.
 - Plastic materials with high temperature resistance and self-extinguishable.
 - All the materials are according to the European Directive RoHS (Restriction of the use of certain hazardous substances in electrical material) and also halogen free.



- ▶ Extended range of different versions.
- ▶ Extended range of accessories are available.

NORMAS

IEC/EN 60269-1
IEC/EN 60269-2
UL4248-1 Portafusibles.
UL486E Terminales de conexión
CSA C22.2 N° 4248-1 Portafusibles
CSA 22.2 N° 65 Terminales de conexión
De acuerdo CE

STANDARDS

IEC/EN 60269-1
IEC/EN 60269-2
UL4248-1 Fuseholders.
UL486E Wiring terminals.
CSA C22.2 N° 4248-1 Fuseholder assemblies
CSA 22.2 N° 65 Wire connectors
According to CE

CERTIFICACIONES Y MARCAS

Certificación / Certification
UL File: E193529

Certificado CB
CB Test Certificate

Certificación RINA para
aplicaciones navales
RINA type approval certification
for marine applications

Certificación / Certification
LLOYD'S





PMX-22

BASES INDUSTRIALES PARA FUSIBLES CILÍNDRICOS
INDUSTRIAL FUSEHOLDERS FOR CYLINDRICAL FUSELINKS

GAMA

RANGE

01.- Estándar / Standard

Referencia / Code	Descripción	Description
485301	BASE PMX-22 UNIPOLAR	PMX-22 FUSEHOLDER 1 POLE
485302	BASE PMX-22 NEUTRO. Sin certificación Rina y Lloyd's	PMX-22 FUSEHOLDER N. Without Rina and Lloyd's certification
485303	BASE PMX-22 UNIPOLAR + NEUTRO	PMX-22 FUSEHOLDER 1 POLE + NEUTRAL
485304	BASE PMX-22 BIPOLAR	PMX-22 FUSEHOLDER 2 POLES
485305	BASE PMX-22 TRIPOLAR	PMX-22 FUSEHOLDER 3 POLES
485306	BASE PMX-22 TRIPOLAR + NEUTRO	PMX-22 FUSEHOLDER 3 POLES + NEUTRAL
485307	BASE PMX-22 TETRAPOLAR	PMX-22 FUSEHOLDER 4 POLES

02.- Con Indicador de fusión / With fusing indicator 230...690 VAC

485308	BASE PMX-22 UNIPOLAR CON INDICADOR	PMX-22 FUSEHOLDER 1 POLE WITH INDICATOR
485309	BASE PMX-22 UNIPOLAR + N CON INDICADOR	PMX-22 FUSEHOLDER 1 POLE + N WITH INDICATOR
485310	BASE PMX-22 BIPOLAR CON INDICADOR	PMX-22 FUSEHOLDER 2 POLES WITH INDICATOR
485311	BASE PMX-22 TRIPOLAR CON INDICADOR	PMX-22 FUSEHOLDER 3 POLES WITH INDICATOR
485312	BASE PMX-22 TRIPOLAR + N CON INDICADOR	PMX-22 FUSEHOLDER 3 POLES + N WITH INDICATOR
485313	BASE PMX-22 TETRAPOLAR CON INDICADOR	PMX-22 FUSEHOLDER 4 POLES WITH INDICATOR

03.- Con Indicador de fusión 24 VDC (Sin certificación Rina y Lloyd's) / With fusing indicator 24 VDC (Without Rina and Lloyd's certification)

485314	BASE PMX-22 UNIPOLAR CON INDICADOR 24VDC	PMX-22 FUSEHOLDER 1 POLE WITH INDICATOR
485315	BASE PMX-22 UNIPOLAR+N C/INDICADOR 24VDC	PMX-22 FUSEHOLDER 1 POLE+N W/INDICATOR 24VDC
485316	BASE PMX-22 BIPOLAR CON INDICADOR 24VDC	PMX-22 FUSEHOLDER 2 POLES W/ INDICATOR 24VDC

04.- Con Indicador de fusión 30...60 VDC (Sin certificación) / With fusing indicator 30...60 VDC (Without certification)

485380	BASE PMX-22 UNIPOLAR CON INDICADOR 60VDC	PMX-22 FUSEHOLDER 1 POLE WITH INDICADOR 60VDC
--------	--	---

05.- Con Micro "Presencia-Precorte-Fusion" / With Microswitch "detection-pre-breaking-fusing"

485320	BASE PMX-22 UNIPOLAR CON MICRO	PMX-22 FUSEHOLDER 1 POLE WITH MICRO
485321	BASE PMX-22 UNIPOLAR + N CON MICRO	PMX-22 FUSEHOLDER 1 POLE + N WITH MICRO
485322	BASE PMX-22 BIPOLAR CON MICRO	PMX-22 FUSEHOLDER 2 POLES WITH MICRO
485323	BASE PMX-22 TRIPOLAR CON MICRO	PMX-22 FUSEHOLDER 3 POLES WITH MICRO
485324	BASE PMX-22 TRIPOLAR + N CON MICRO	PMX-22 FUSEHOLDER 3 POLES + N WITH MICRO
485325	BASE PMX-22 TETRAPOLAR CON MICRO	PMX-22 FUSEHOLDER 4 POLES WITH MICRO

06.- Con Micro "Solo-Fusion" / With Microswitch "only-fusing"

485326	BASE PMX-22 UNIPOLAR CON MICRO SOLO-FUSION	PMX-22 FUSEHOLDER 1 POLE , MICRO ONLY FUSING
485327	BASE PMX-22 UNIPOLAR+N C/MICRO SOLO-FUSION	PMX-22 FUSEHOLDER 1 POLE + N , MICRO ONLY FUSING
485328	BASE PMX-22 BIPOLAR CON MICRO SOLO-FUSIÓN	PMX-22 FUSEHOLDER 2 POLES , MICRO ONLY FUSING
485329	BASE PMX-22 TRIPOLAR CON MICRO SOLO-FUSIÓN	PMX-22 FUSEHOLDER 3 POLES , MICRO ONLY FUSING
485330	BASE PMX-22 TRIPOLAR + N C/MICRO SOLO-FUSIÓN	PMX-22 FUSEHOLDER 3 POLES + N, MICRO ONLY FUSING
485331	BASE PMX-22 TETRAPOLAR C/MICRO SOLO-FUSIÓN	PMX-22 FUSEHOLDER 4 POLES , MICRO ONLY FUSING

07.- Accesorios/ Accessories

480005	PINZA DE UNIÓN MULTIPOLAR	PINS FOR MULTIPOLE ASSEMBLY
485356	PASADOR DE UNIÓN MULTIPOLAR	HANDLE TIES FOR MULTIPOLE ASSEMBLY
485357	PASADOR DE UNIÓN MICROS	TIES FOR MICROSWITCHES ASSEMBLY
485358	PMX-22 SOPORTE CANDADO	LOCK SUPPORT
485359	MICRO SÓLO FUSIÓN 1P	1 POLE MICRO ONLY FUSION
485360	MICRO SÓLO FUSIÓN 3P	3 POLES MICRO ONLY FUSION
485361	MICRO SÓLO FUSIÓN 3P (2 MICROS)	3 POLES - DOUBLE MICRO ONLY FUSING
485362	EXTENSIÓN MICRORRUPTOR 1P	MICRO 1 POLE EXTENSION
485363	EXTENSIÓN MICRORRUPTOR 3P	MICRO 3 POLES EXTENSION
485364	RECAMBIO IND. FUSIÓN NEON 120/690VAC	REPLACEMENT FUSING INDICATOR 120/690 VAC
485365	RECAMBIO IND. FUSION LED 24 VDC	REPLACEMENT FUSING INDICATOR 24 VDC
485366	ACCESORIO PROTECCIÓN ESPECIAL IP20	SPECIAL IP20 PROTECTION ACCESSORY
485367	ACCESORIO CONEXION ESP. TORNILLO	SPECIAL ACCESSORY SCREW CONNECTION
485371	ACCESORIO PROTECCIÓN TORNILLO	ACCESSORY SCREW PROTECTION
485372	MÓDULO DE PRECORTE	PRE-BREAKING MODULE





PMX-22

BASES INDUSTRIALES PARA FUSIBLES CILÍNDRICOS
INDUSTRIAL FUSEHOLDERS FOR CYLINDRICAL FUSELINKS

CARACTERÍSTICAS TÉCNICAS	TECHNICAL FEATURES																								
Intensidad asignada: 100 A* * Admite fusibles de 125A	Rated current: 100 A* * Accept 125A fuse-links																								
Tensión asignada IEC: 690V AC / 750V DC Tensión asignada UL-CSA: 750V AC	Rated voltage IEC: 690V AC / 750V DC Rated voltage UL-CSA: 750V AC																								
Potencia disipable asignada: 9,5 W Potencia disipable máxima: 12 W	Rated power dissipation: 9,5 W Maximum power dissipation: 12 W																								
Valor potencia disipada por polo (Con tubo neutro): 80% I_n 1,38 W 100% I_n 2,18 W	Power dissipation per pole (With neutral link): 80% I_n 1,38 W 100% I_n 2,18 W																								
Categoría de empleo según IEC/EN 60947-3: AC-21B 690V	Utilization category as per EN 60947-3: AC-21B 690V																								
Grado de polución: 3	Pollution degree: 3																								
Índice de protección: IP20 . Para protección de cable de $\varnothing \leq 6\text{mm}$ es necesario un accesorio para garantizar IP20 en bornes. (Fig 5)	Protection index: IP20 . For \varnothing cable protection $\leq 6\text{mm}$, an accessory is required to ensure IP20 at terminals (Fig. 5)																								
Tensión asignada soportada al impulso: 6 kV U imp.	Rated impulse withstand voltage: 6 kV U imp.																								
Resistencia al cortocircuito: - Fusible Industrial: 120 kA - Fusible Semiconductor: 200 kA	Withstand rating (SCCR): - Industrial fuselink: 120 kA - Semiconductor fuselink: 200 kA																								
Índice de inflamabilidad IEC 60695 GWFI: 960°	Flammability index IEC 60695 GWFI: 960°																								
Temperatura ambiente de servicio: - 40°C 70°C (Con accionamiento del tirador) - 50°C 80°C (Sin accionamiento del tirador)	Ambient temperature of service: - 40°C 70°C (With carrier operation) - 50°C 80°C (Without carrier operation)																								
Temperatura de almacenado: - 50°C 80°C	Storage temperature: - 50°C 80°C																								
Coefficiente de aplicación en bases multipolares: <table border="1" data-bbox="194 1487 711 1644"> <thead> <tr> <th>Nº de polos</th> <th>Factor reducción de la corriente</th> </tr> </thead> <tbody> <tr> <td>1 ... 4</td> <td>1</td> </tr> <tr> <td>5 ... 7</td> <td>0,95</td> </tr> <tr> <td>≥ 8</td> <td>0,90</td> </tr> </tbody> </table>	Nº de polos	Factor reducción de la corriente	1 ... 4	1	5 ... 7	0,95	≥ 8	0,90	Derating by number of poles: <table border="1" data-bbox="858 1487 1375 1644"> <thead> <tr> <th>Nº of poles</th> <th>Derating factor of current</th> </tr> </thead> <tbody> <tr> <td>1 ... 4</td> <td>1</td> </tr> <tr> <td>5 ... 7</td> <td>0,95</td> </tr> <tr> <td>≥ 8</td> <td>0,90</td> </tr> </tbody> </table>	Nº of poles	Derating factor of current	1 ... 4	1	5 ... 7	0,95	≥ 8	0,90								
Nº de polos	Factor reducción de la corriente																								
1 ... 4	1																								
5 ... 7	0,95																								
≥ 8	0,90																								
Nº of poles	Derating factor of current																								
1 ... 4	1																								
5 ... 7	0,95																								
≥ 8	0,90																								
Corrección de corriente admisible en función de la temperatura ambiente: <table border="1" data-bbox="253 1776 654 2011"> <tbody> <tr><td>20°C</td><td>1</td></tr> <tr><td>30°C</td><td>0,95</td></tr> <tr><td>40°C</td><td>0,90</td></tr> <tr><td>50°C</td><td>0,80</td></tr> <tr><td>60°C</td><td>0,70</td></tr> <tr><td>70°C</td><td>0,60</td></tr> </tbody> </table>	20°C	1	30°C	0,95	40°C	0,90	50°C	0,80	60°C	0,70	70°C	0,60	Correction of the admissible current in function of the ambient temperature: <table border="1" data-bbox="917 1776 1318 2011"> <tbody> <tr><td>20°C</td><td>1</td></tr> <tr><td>30°C</td><td>0,95</td></tr> <tr><td>40°C</td><td>0,90</td></tr> <tr><td>50°C</td><td>0,80</td></tr> <tr><td>60°C</td><td>0,70</td></tr> <tr><td>70°C</td><td>0,60</td></tr> </tbody> </table>	20°C	1	30°C	0,95	40°C	0,90	50°C	0,80	60°C	0,70	70°C	0,60
20°C	1																								
30°C	0,95																								
40°C	0,90																								
50°C	0,80																								
60°C	0,70																								
70°C	0,60																								
20°C	1																								
30°C	0,95																								
40°C	0,90																								
50°C	0,80																								
60°C	0,70																								
70°C	0,60																								





PMX-22

BASES INDUSTRIALES PARA FUSIBLES CILÍNDRICOS
INDUSTRIAL FUSEHOLDERS FOR CYLINDRICAL FUSELINKS

CARACTERÍSTICAS DE UTILIZACIÓN

APPLICATION CHARACTERISTICS

Fijación sobre rail DIN/EN Estándar
DIN 46277/1-3 (EN50022)
Clip con fijación de 2 posiciones

For mounting on DIN/EN standard rail
DIN 46277/1-3 (EN50022)
Fixation clip with 2 positions

- Capacidad de embornado / [Connecting wire](#):

	Capacidad de embornado / Connecting wire Utilizar cables de cobre / Copper wires only		Conexionado / Wiring
	Métrico / Metric	AWG	
1 Cable / Wire	1,5...50mm ² Rígido / Solid 1,5...35mm ² Flexible / Stranded	#1...16 AWG Rígido / Solid #2...16 AWG Flexible / Stranded	
2 Cables / Wires (Misma sección y tipo) (Same cross-section and type)	1,5...16mm ² Rígido / Solid 1,5...10mm ² Flexible / Stranded	#6...16 AWG Rígido / Solid #6...16 AWG Flexible / Stranded	

- El uso de terminales de conexión puede permitir aumentar la sección de cable de embornado.

- The use of wire-end terminals may allow to increase the connecting wire section.

- Montaje de terminales recomendado:

- Wire-end terminals recommended mounting:

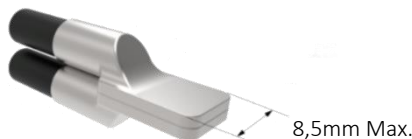

- El uso de terminales podría no garantizar el grado de protección IP20.

- The use of wire-end terminals could not guarantee the IP20 protection degree.

- Se recomienda el uso de punteras en cables de sección $\leq 2,5\text{mm}^2$

- Is recommended use of ferrules in wires with section $\leq 2,5\text{mm}^2$



- El producto se suministra con los bornes abiertos y listos para conectar.

- The product is delivered with the terminals opened and ready to connect.

Par de apriete en bornes: **3,5 ... 4 Nm / 31 ... 35 lb.in**
Tornillos con huella combinada: **RANURA + PZ2**

Tightening torque on terminals: **3,5 ... 4 Nm / 31 ... 35 lb.in**
Screws with a combined head: **SLOT + PZ2**

Posibilidad de uniones multipolares mediante accesorios de fácil montaje: [Ver referencias en GAMA](#). [Ver montaje en fig. nº 1](#)

Easy multipolar assembly for end users by the use of accessories: [See references on RANGE](#). [See assembly in fig. nº 1](#)

Bases con indicador luminoso de fusión:

Fuse holders with fuse indicator:

- VERSIÓN NEON STANDARD 230 ... 690V.
- VERSIÓN LED 12 ... 24 VDC.
- VERSION LED 30 ... 60 VDC.

- NEON STANDARD VERSION 230 ... 690V.
- LED VERSION 12 ... 24 VDC.
- LED VERSION 30 ... 60 VDC.

[Ver referencias en GAMA](#).

[See references on RANGE](#).





PMX-22

BASES INDUSTRIALES PARA FUSIBLES CILÍNDRICOS
INDUSTRIAL FUSEHOLDERS FOR CYLINDRICAL FUSELINKS

- BASES CON MICRORRUPTOR 5A – 250V

Contactos NC (Normalmente Cerrado) NO (Normalmente Abierto)
- Versión Presencia – Precorte – Fusión
- Versión solo fusión

- Detecta solo la fusión del cartucho fusible.
- Posible montar accesorio en bases estándar.

- Ambas versiones se suministran con 3 terminales fast-on pre-aislados 2,8 x 0,5.
- Ver referencias en GAMA. Ver montaje en Fig. Nº 2.

Todas las versiones van equipadas con porta-etiquetas para la identificación del circuito.

- Tamaño adecuado de etiqueta: 25x10 mm.
- Ver montaje en Fig. nº3.

Disponible accesorio para bloqueo de la base mediante candado.
(máximo 3 candados de \varnothing 4mm)
▪Ver montaje en Fig. Nº4

- FUSE HOLDERS WITH MICROSWITCH 5A – 250V

NC (Normally closed) NO (Normally Open) Contacts
- Fusing + pre-breaking + fuse link detection
- Only fusing

- Only detection of fuse link operation.
- Also as accessory mounted on standard fuse holders.

- Both versions delivered with 3 pre-insulated terminals (fast-on 2,8 x 0,5).
- See references on RANGE. See assembly in fig. nº 2.

All the versions with label holder for a better circuit identification.

- Suitable size for label: 25x10 mm.
- See operation in Fig. nº 3.

Accessory available to lock the fuse holder by a padlock. (max. 3 padlocks of \varnothing 4mm)
▪See operation in Fig. nº 4.

PESOS

WEIGHT

		Estándar / Con indicador Standard / With indicator	Con microrruptor With microswitch
Pesos de producto sin embalaje. Products without packing	1P	155 gr.	165 gr.
	N	170 gr.	-
	1P+N	325 gr.	335 gr.
	2P	310 gr.	330 gr.
	3P	465 gr.	495 gr.
	3P+N	635 gr.	665 gr.
	4P	620 gr.	660 gr.

DIMENSIONES

DIMENSIONS

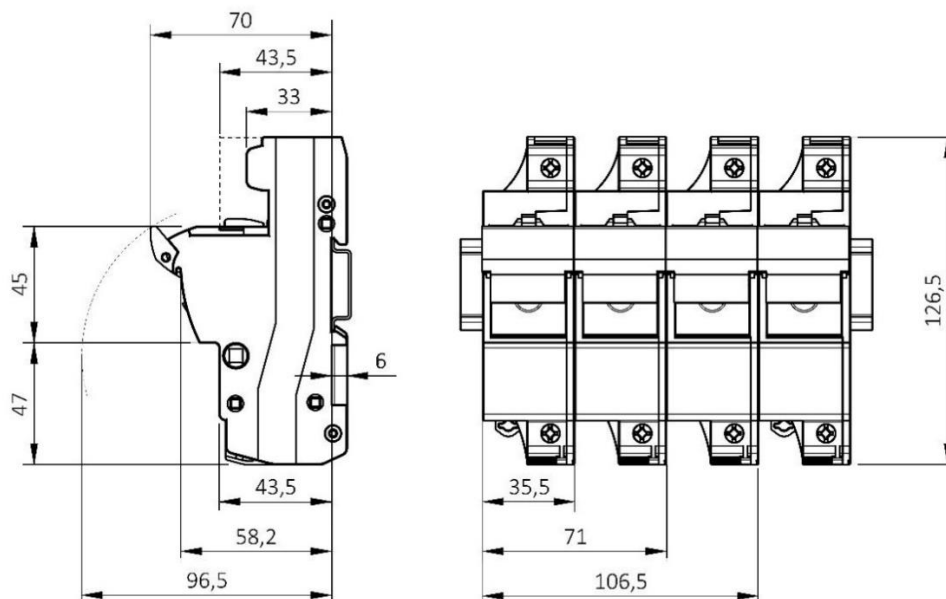



PMX-22

BASES INDUSTRIALES PARA FUSIBLES CILÍNDRICOS
INDUSTRIAL FUSEHOLDERS FOR CYLINDRICAL FUSELINKS

Fig. 1 Ensamblado multipolar

▪ Sistema estándar de DF, 3 clips y 1 pasador entre cada unión entre polos.

Fig.1 Multipolar assembly

▪ Standard system by DF, 3 clips and 1 pin for each union between poles.

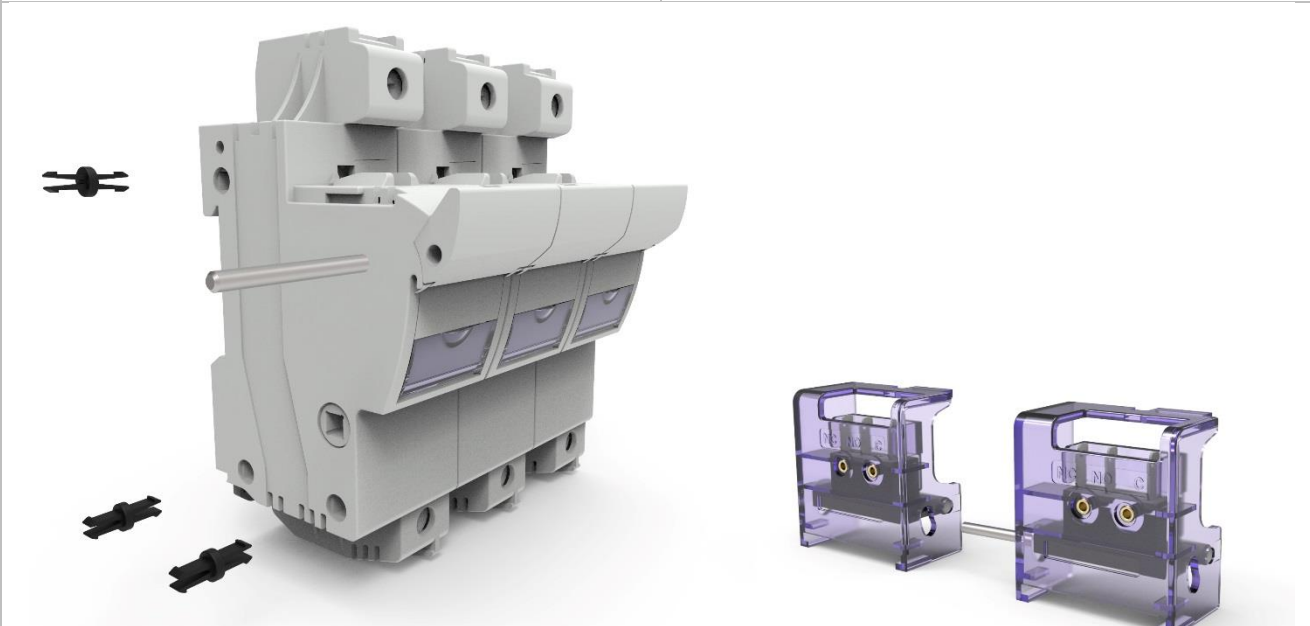

Fig. 2 Montaje del microrruptor

▪ Posicionar el Micro verticalmente sobre las guías, y desplazar horizontalmente hasta su fijación.
* Para accesorio Solo/fusión, primero es necesario montar la leva en su alojamiento.

Fig.2 Microswitch mounting

▪ Put on the microswitch on the guides, and push in horizontal movement to the final position.
* For Only-Fusion accessory, first mount the Lifter in his place.





PMX-22

BASES INDUSTRIALES PARA FUSIBLES CILÍNDRICOS
INDUSTRIAL FUSEHOLDERS FOR CYLINDRICAL FUSELINKS

Fig. 2.1 Extensión accesorio microrruptor

Fig.2.1 Extension microswitch accessory

Número de uniones multipolares permitidas con accesorio extensión micro unipolar: **2 máx.**

Number of multipolar assemblies allowed with extension accessory microswitch unipolar: **max. 2**



x2 Max.

Número de uniones multipolares permitidas con accesorio extensión micro tripolar: **1 máx.**

Number of multipolar assemblies allowed with extension accessory microswitch tripolar: **max. 1**

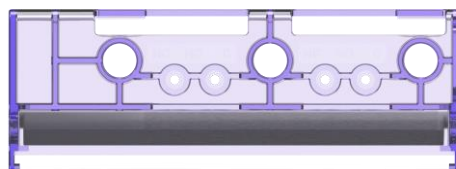

x1 Max.

Montaje accesorio

Accessory assembly

Microrruptor
Microswitch

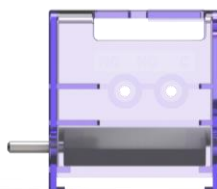

Accesorio extensión
Extension accessory

Montaje de 2 accesorios:
Siempre uno a cada lado del microrruptor.

2 accessories assembly:
Always one to each side of the microswitch

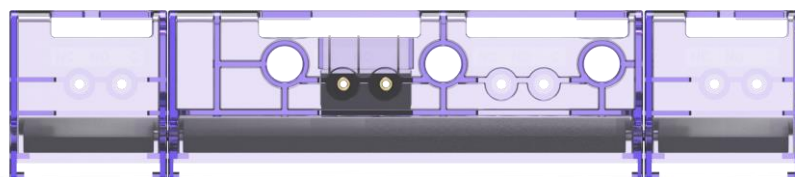
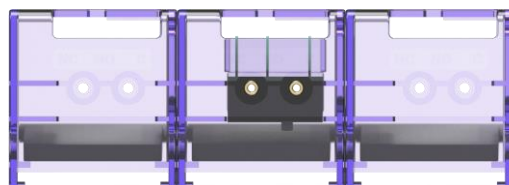



PMX-22

BASES INDUSTRIALES PARA FUSIBLES CILÍNDRICOS
INDUSTRIAL FUSEHOLDERS FOR CYLINDRICAL FUSELINKS

- Los fusibles con percutor deben montarse en bases con microinterruptor.
- La flecha indica la correcta posición del percutor.

- Fuse links with striker must be mounted on fuse holders with microswitch system.
- The arrow indicates the correct position of the striker.

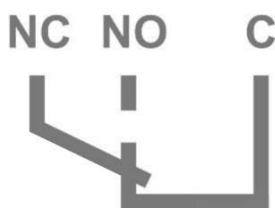

Fig. 3 Identificación con etiqueta

Fig.3 Identification by label

- Abrir la pieza porta-etiquetas con la base totalmente cerrada, o totalmente abierta, posicionar la etiqueta en el interior y cerrar.

- Open the label-holder part when the fuseholder is totally closed or totally open, put on the label and close.





PMX-22

BASES INDUSTRIALES PARA FUSIBLES CILÍNDRICOS
INDUSTRIAL FUSEHOLDERS FOR CYLINDRICAL FUSELINKS

Fig. 4 Bloqueo mediante candado

- Para evitar la maniobra y conexión, con la base abierta, posicionar el accesorio “Soporte candado”, haciéndolo deslizar por las guías, y cubriendo la zona del cartucho fusible. (Se puede utilizar con y sin fusible en el interior.
- Introducir el candado por las dos aberturas simétricas y cerrarlo.

Fig.4 Locking means a padlock

- To avoid the operation and connection when the fuse holder is open, put on the accessory “Padlock support” sliding it for the guides, and covering the fuse link zone. (Is possible the use with or without fuse link)
- Introduce the padlock trough the symmetrical holes and close it.

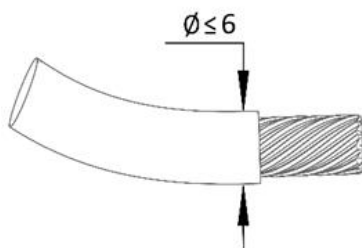

Fig. 5 Protección IP20 especial

- Posicionar el reductor en la entrada del cable cuando se necesite conseguir un grado de protección IP20 con cables finos.

Fig.5 Special protection IP20

- Position the reducer accessory at the terminals when an IP20 protection is required with thin cables.



Para obtener un grado IP20 con protección de cable de $\varnothing \leq 6$ mm, utilizar el **accesorio de protección especial**.

To obtain an IP20 rating with cable protection of $\varnothing \leq 6$ mm, use the **special protection accessory**.

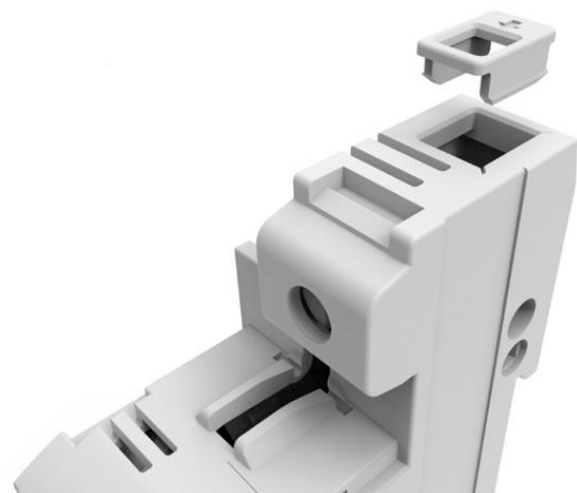



PMX-22

BASES INDUSTRIALES PARA FUSIBLES CILÍNDRICOS
INDUSTRIAL FUSEHOLDERS FOR CYLINDRICAL FUSELINKS

Fig.6 Accesorio especial conexión tornillo

Fig.6 Special Accessory screw connection

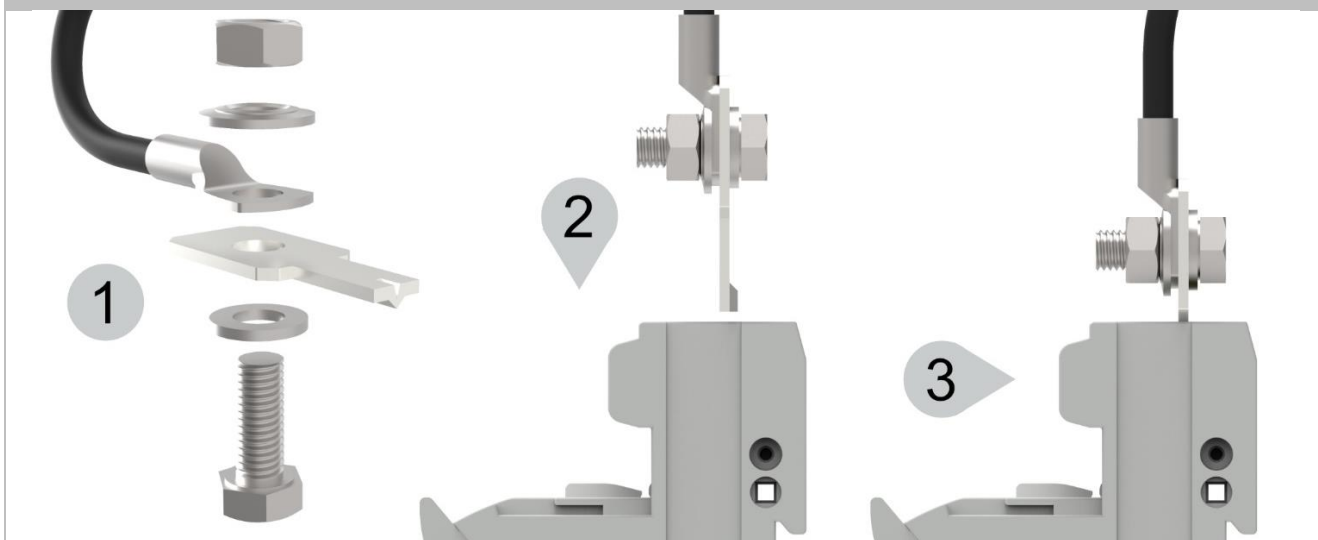

- 1.- Montar accesorio sobre cable / Mount the accessory in the wire .. 10Nm
- 2.- Conectar en la base / Wiring in the fuseholder
- 3.- Aplicar par de apriete / Apply tightening torque 3,5 – 4 Nm

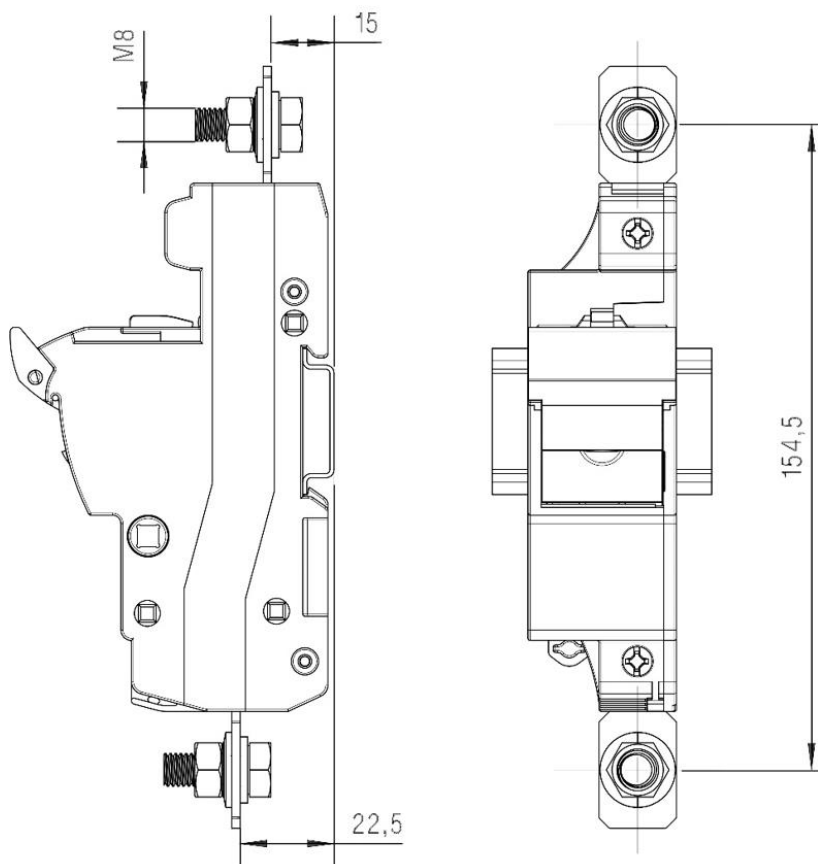



PMX-22

BASES INDUSTRIALES PARA FUSIBLES CILÍNDRICOS
INDUSTRIAL FUSEHOLDERS FOR CYLINDRICAL FUSELINKS

Fig. 7 Módulo de precorte

- Módulo accesorio que al unirlo a cualquier otra base Portafusible de su gama, ofrece una señal extra de Precorte.
- Kit de ensamblado incluido en el producto.

Fig.7 Pre-breaking module

- Accessory module which attached to any other fuse holder of its range, offers an extra pre-breaking signal.
- Assembly kit is included in the product.

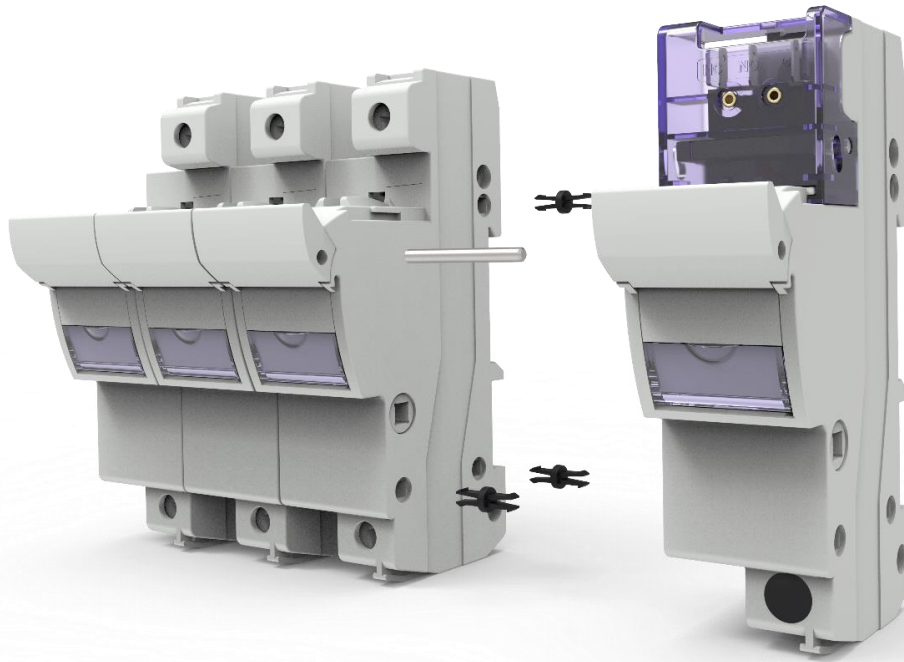

Fig. 8 Accesorio protección tornillos

- Accesorio de protección que evita la manipulación de los tornillos y mejora el grado de protección.

Fig.8 Screws' protection accessory

- Protection accessory to avoid the screws manipulation and improve the protection degree.





PMX-22

BASES INDUSTRIALES PARA FUSIBLES CILÍNDRICOS
INDUSTRIAL FUSEHOLDERS FOR CYLINDRICAL FUSELINKS

Fig. 9 Instrucciones reemplazo indicador de fusión.

Fig.9 Fusing Indicator replacement instructions.

Abrir la base portafusibles.

Open the fuseholder.

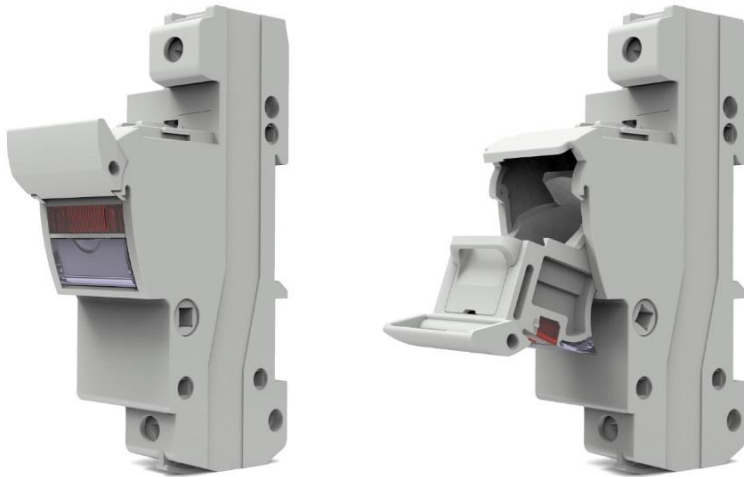

Usando un destornillador plano, extraer la tapeta con una ligera rotación de la herramienta.

Using a flat screwdriver, remove the cover with a slight rotation of the tool.

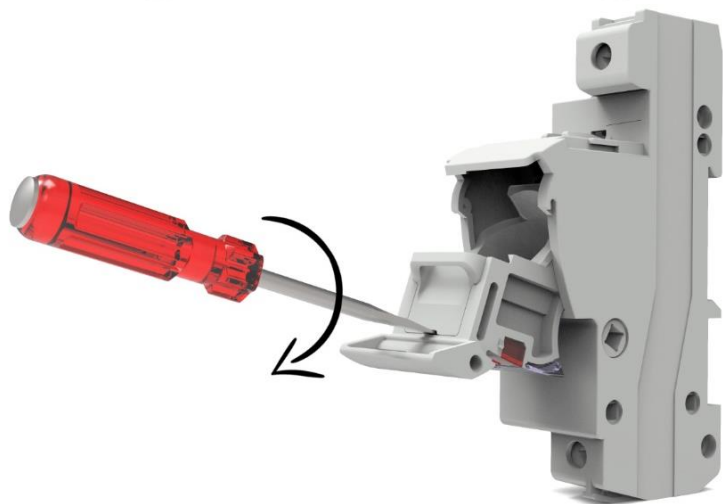

Cambiar el indicador de fusión e introducir de nuevo la tapeta en el tirador.

Replace the fusing indicator and enter the cover on the handle.

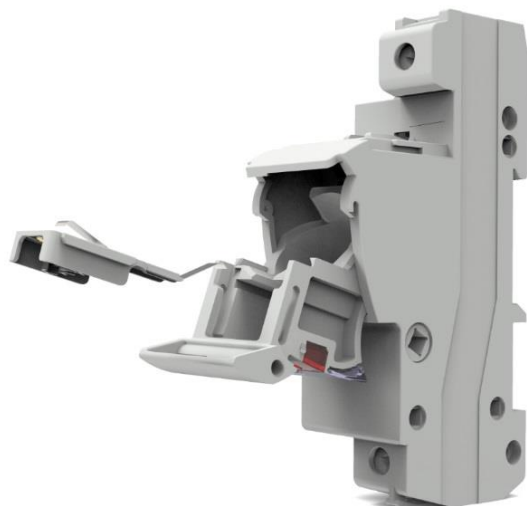

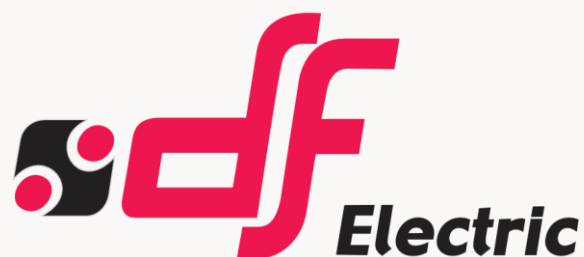

PROTECTING THE WORLD

OFICINA CENTRAL Y FÁBRICA HEAD OFFICE AND FACTORY

SILICI, 67-69
08940 CORNELLA DE LLOBREGAT
BARCELONA · SPAIN
Tel. +34 93 377 85 85
Fax +34 93 377 82 82

VENTAS INTERNACIONAL INTERNATIONAL SALES

Tel. +34 93 475 08 64
Fax +34 93 480 07 75
export@dfelectric.es

VENTAS NACIONAL NATIONAL SALES

Tel. 93 475 08 64
Fax 93 480 07 76
comercial@dfelectric.es

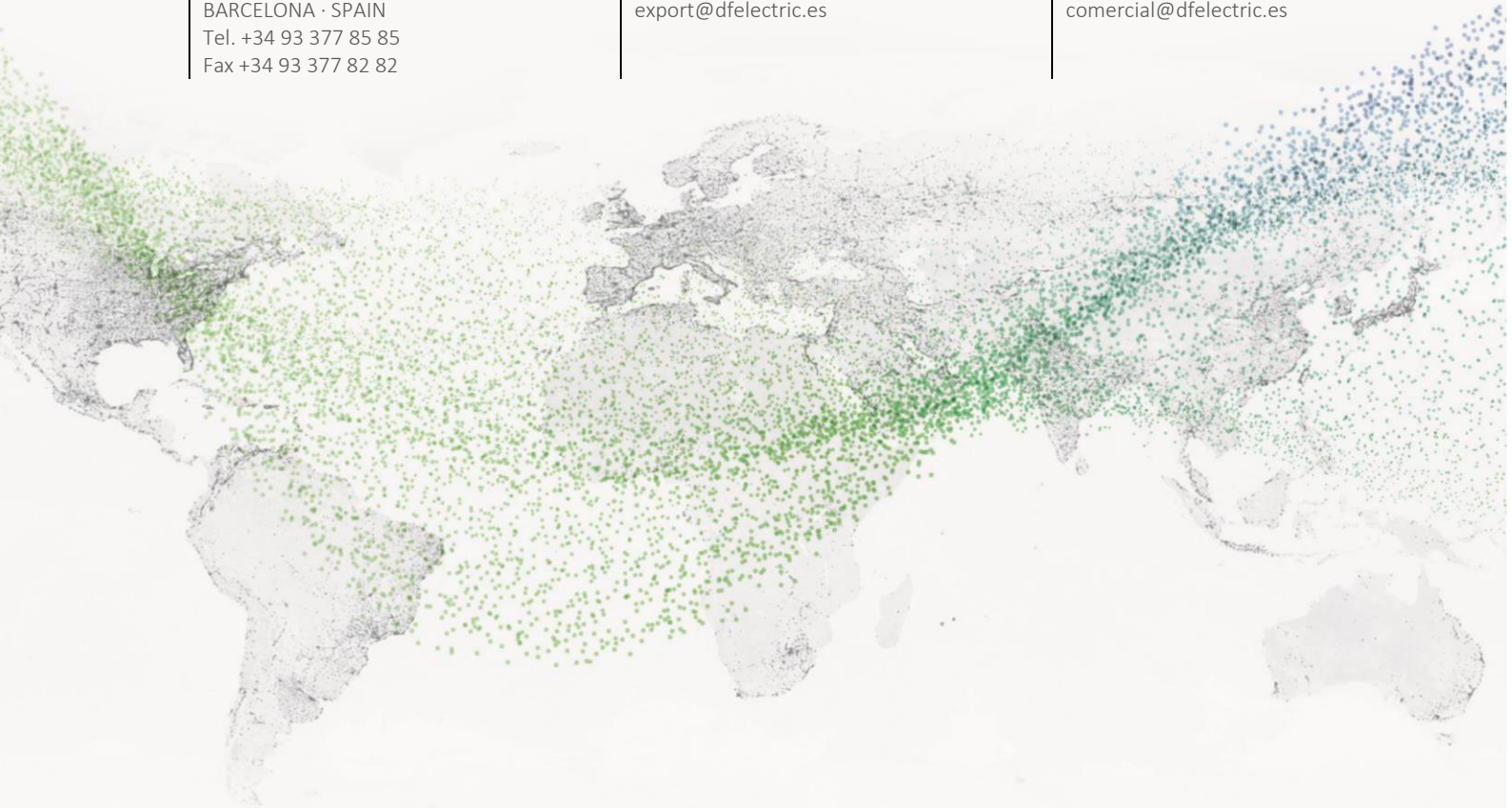

www.dfelectric.es

