

BASES INDUSTRIALES PARA
FUSIBLES CILÍNDRICOS

INDUSTRIAL FUSEHOLDERS
FOR CYLINDRICAL FUSELINKS

PMX-CC



**PROTECTING
THE WORLD**



Oficina Central y Fábrica / Head Office

Silici, 67-69 08940 Cornellà de Llobregat -
Barcelona (SPAIN)

Tel. (+34) 93 377 85 85 - Fax. (+34) 93 377 82 82

info@dfelectric.es

www.dfelectric.es



PMX-CC

BASES INDUSTRIALES PARA FUSIBLES CILÍNDRICOS
INDUSTRIAL FUSEHOLDERS FOR CYLINDRICAL FUSELINKS

Los datos reflejados en esta ficha técnica están sujetos a la correcta instalación del producto de acuerdo con las instrucciones del fabricante, normas y reglamentos de instalación y conforme a las reglas profesionales, debidamente mantenido y utilizado en las aplicaciones para las que está previsto.

Los productos descritos en este documento han sido diseñados, desarrollados y ensayados de acuerdo a una normativa específica. Se consideran componentes que son integrados formando parte de una instalación, máquina o equipo.

La garantía y responsabilidad del correcto funcionamiento general del conjunto corresponde al fabricante de la instalación, máquina o equipo.

DF Electric S.A. no puede garantizar las características de una instalación, máquina o equipo que ha sido diseñado por un tercero. Una vez que se ha seleccionado un producto, el usuario debe comprobar que es apropiado para su aplicación, mediante las verificaciones y/o ensayos que considere oportunos.

DF ELECTRIC se reserva el derecho a cambiar las dimensiones, especificaciones, materiales o el diseño de sus productos en cualquier momento sin previo aviso.

The data reflected in this technical record are subject to the correct installation of the product in accordance with manufacturer's instructions, relevant installation standards and professional practices, maintained and used in applications for which they were made.

The products described in this document have been designed, developed and tested in accordance with specific standard. They are considered components that are integrated as part of installation, machine or equipment.

The correct general operation of the referred product is responsibility of the manufacturer of the installation, machine or equipment.

DF Electric SA cannot guarantee the characteristics of an installation, machine or equipment that has been designed by a third party. Once a product has been selected, the user must verify that it is appropriate for its application, through the verifications and/or tests that it deems appropriate.

DF ELECTRIC retains the right to change the dimensions, specifications, materials or design of its products at any time with or without notice.



De acuerdo a la directiva de residuos de aparatos eléctricos y electrónicos (WEEE) el material eléctrico no debe formar parte de los residuos habituales.

Este símbolo alerta a los usuarios de que estos productos deben reciclarse según la normativa local medioambiental de eliminación de residuos



According to the waste of electrical and electronic equipment directive, electrical material should not be part of the usual waste.

This symbol alerts users that these products should be recycled according to local environmental waste disposal regulations.



El logotipo "experto electrotécnico" marcado sobre los productos incluidos en la presente ficha técnica indica que la instalación de estos productos debe ser realizada por personal experto con conocimientos especializados.



The "electro technical expert" logo marked on the products included in this data sheet indicates that the installation of these products must be carried out by expert personnel with specialized knowledge.



Para evitar riesgo eléctrico, realice la instalación sin tensión.



To prevent electrical hazards, carry out the installation without voltage.



Advertencias de seguridad



Safety notice





PMX-CC

BASES INDUSTRIALES PARA FUSIBLES CILÍNDRICOS
INDUSTRIAL FUSEHOLDERS FOR CYLINDRICAL FUSELINKS

DESCRIPCIÓN DEL PRODUCTO

- ▶ Bases portafusibles modulares para utilizar con fusibles cilíndricos talla CLASE CC según norma UL4248-4.
- ▶ Diseño compacto, de dimensiones reducidas.
- ▶ Zonas de ventilación optimizadas para una mejor disipación del calor.
- ▶ Fabricadas con materiales de calidad:
 - Contactos de cobre electrolítico plateados.
 - Materiales plásticos auto extingüibles y de alta resistencia a la temperatura.
 - Todos los materiales utilizados son conformes a la Directiva europea RoHS (Restricción de ciertas sustancias peligrosas en el material eléctrico) así como libres de halógenos.



- ▶ Amplia gama de diferentes versiones.
- ▶ Amplia gama de accesorios disponible.

PRODUCT DESCRIPTION

- ▶ Modular fuse holders for cylindrical fuse links size CLASS CC according UL4248-4 standard.
- ▶ Compact design, with reduced distances.
- ▶ Ventilation zones optimized for a better heat dissipation
- ▶ Manufactured with a high quality materials
 - Silver plated copper contacts.
 - Plastic materials with high temperature resistance and self-extinguishable.
 - All the materials are according to the European Directive RoHS (Restriction of the use of certain hazardous substances in electrical material) and also halogen free.



- ▶ Extended range of different versions.
- ▶ Extended range of accessories are available.

NORMAS

UL4248-1 Requisitos Generales
UL4248-4 Portafusibles
UL486E Terminales de conexión
CSA C22.2 N° 4248-1 Portafusibles
CSA 22.2 N° 65 Terminales de conexión

STANDARDS

UL4248-1 General Requirements
UL4248-4 Fuseholders
UL486E Wiring terminals
CSA C22.2 N° 4248-1 Fuseholder assemblies
CSA 22.2 N° 65 Wire connectors

CERTIFICACIONES Y MARCAS

Certificación UL / UL
Certification File: E193529



Certificación CSA / CSA Certification
File: 221680



CERTIFICATIONS & MARKS





PMX-CC

BASES INDUSTRIALES PARA FUSIBLES CILÍNDRICOS
INDUSTRIAL FUSEHOLDERS FOR CYLINDRICAL FUSELINKS

GAMA

RANGE

01.- PMX-CC Estándar / Standard PMX-CC

Referencia Code	Módulo Module	Descripción	Description
485181	1	BASE PMX-CC UNIPOLAR	PMX-CC FUSEHOLDER 1 POLE
485184	2	BASE PMX-CC BIPOLAR	PMX-CC FUSEHOLDER 2 POLES
485185	3	BASE PMX-CC TRIPOLAR	PMX-CC FUSEHOLDER 3 POLES

02.- PMX-CC con Indicador de fusión / PMX-CC with fusing indicator

Referencia Code	Módulo Module	Descripción	Description
485188	1	BASE PMX-CC UNIPOLAR CON INDICADOR	PMX-CC FUSEHOLDER 1 POLE WITH INDICATOR
485190	2	BASE PMX-CC BIPOLAR CON INDICADOR	PMX-CC FUSEHOLDER 2 POLES WITH INDICATOR
485191	3	BASE PMX-CC TRIPOLAR CON INDICADOR	PMX-CC FUSEHOLDER 3 POLES WITH INDICATOR

03.- Accesorios / Accessories

Referencia Code	Descripción	Description
480005	PINZA PARA UNIÓN MULTIPOLAR	PINS FOR MULTIPOLE ASSEMBLY
485050	PASADOR PARA UNIÓN MULTIPOLAR	HANDLE TIES FOR MULTIPOLE ASSEMBLY
485051	ACCESORIO DE BLOQUEO	LOCK ACCESSORY
485052	ACCESORIO PROTECCIÓN ESPECIAL IP20	SPECIAL IP20 PROTECTION ACCESSORY
485053	ACCESORIO SEPARADOR FASES	PHASE SEPARATOR ACCESSORY
485054	RECAMBIO INDICADOR DE FUSIÓN	REPLACEMENT FUSING INDICATOR
485656	ACCESORIO PROTECCIÓN TORNILLOS	SCREWS PROTECTION ACCESSORY





PMX-CC

BASES INDUSTRIALES PARA FUSIBLES CILÍNDRICOS
INDUSTRIAL FUSEHOLDERS FOR CYLINDRICAL FUSELINKS

CARACTERÍSTICAS TÉCNICAS

TECHNICAL FEATURES

INTENSIDAD ASIGNADA: 30A	RATED CURRENT: 30A																								
TENSION ASIGNADA: 600V AC / 600V DC	RATED VOLTAGE: 600V AC / 600V DC																								
INDICE DE PROTECCIÓN: IP20 . Para protección de cable de $\varnothing \leq 4,5\text{mm}$ es necesario un accesorio para garantizar IP20 en bornes. (Fig 4)	PROTECTION INDEX: IP20 . For \varnothing cable protection $\leq 4,5\text{mm}$, an accessory is required to ensure IP20 at terminals (Fig. 4)																								
RIGIDEZ DIELECTRICA: 2200 V	DIELECTRIC STRENGTH: 2200 V																								
RESISTENCIA AL CORTOCIRCUITO CON FUSIBLE: 200 kA rms sym.	WITHSTAND RATING: 200 kA rms sym.																								
- TEMPERATURA AMBIENTE DE SERVICIO: - 40°C 70°C (Con accionamiento del tirador) - 50°C 80°C (Sin accionamiento del tirador) - TEMPERATURA DE ALMACENADO: - 50°C .. 80°C	- AMBIENT TEMPERATURE OF SERVICE: - 40°C 70°C (With carrier operation) - 50°C 80°C (Without carrier operation) - STORAGE TEMPERATURE: - 50°C.....80°C																								
COEFICIENTE DE APLICACIÓN EN BASES MULTIPOLARES: <table border="1" data-bbox="194 1330 686 1509"> <thead> <tr> <th>Nº de Polos</th> <th>Factor reducción de la corriente</th> </tr> </thead> <tbody> <tr> <td>1 ... 4</td> <td>1</td> </tr> <tr> <td>5 ... 7</td> <td>0,95</td> </tr> <tr> <td>≥ 8</td> <td>0,90</td> </tr> </tbody> </table>	Nº de Polos	Factor reducción de la corriente	1 ... 4	1	5 ... 7	0,95	≥ 8	0,90	DERATING BY NUMBER OF POLES: <table border="1" data-bbox="849 1330 1340 1509"> <thead> <tr> <th>Nº de Polos</th> <th>Factor reducción de la corriente</th> </tr> </thead> <tbody> <tr> <td>1 ... 4</td> <td>1</td> </tr> <tr> <td>5 ... 7</td> <td>0,95</td> </tr> <tr> <td>≥ 8</td> <td>0,90</td> </tr> </tbody> </table>	Nº de Polos	Factor reducción de la corriente	1 ... 4	1	5 ... 7	0,95	≥ 8	0,90								
Nº de Polos	Factor reducción de la corriente																								
1 ... 4	1																								
5 ... 7	0,95																								
≥ 8	0,90																								
Nº de Polos	Factor reducción de la corriente																								
1 ... 4	1																								
5 ... 7	0,95																								
≥ 8	0,90																								
CORRECIÓN DE CORRIENTE ADMISIBLE EN FUNCIÓN DE LA TEMPERATURA AMBIENTE: <table border="1" data-bbox="280 1686 644 1872"> <tbody> <tr><td>20°C</td><td>1</td></tr> <tr><td>30°C</td><td>0,95</td></tr> <tr><td>40°C</td><td>0,90</td></tr> <tr><td>50°C</td><td>0,80</td></tr> <tr><td>60°C</td><td>0,70</td></tr> <tr><td>70°C</td><td>0,60</td></tr> </tbody> </table>	20°C	1	30°C	0,95	40°C	0,90	50°C	0,80	60°C	0,70	70°C	0,60	CORRECTION OF THE ADMISSIBLE CURRENT IN FUNCTION OF THE AMBIENT TEMPERATURE: <table border="1" data-bbox="938 1686 1302 1872"> <tbody> <tr><td>20°C</td><td>1</td></tr> <tr><td>30°C</td><td>0,95</td></tr> <tr><td>40°C</td><td>0,90</td></tr> <tr><td>50°C</td><td>0,80</td></tr> <tr><td>60°C</td><td>0,70</td></tr> <tr><td>70°C</td><td>0,60</td></tr> </tbody> </table>	20°C	1	30°C	0,95	40°C	0,90	50°C	0,80	60°C	0,70	70°C	0,60
20°C	1																								
30°C	0,95																								
40°C	0,90																								
50°C	0,80																								
60°C	0,70																								
70°C	0,60																								
20°C	1																								
30°C	0,95																								
40°C	0,90																								
50°C	0,80																								
60°C	0,70																								
70°C	0,60																								





CARACTERÍSTICAS DE UTILIZACIÓN

APPLICATION CHARACTERISTICS

Fijación sobre rail DIN/EN estándar:
DIN 46277/1-3 (EN50022)

For mounting on DIN/EN standard rail:
DIN 46277/1-3 (EN50022)

Fijación tornillo disponible con accesorio (Fig. 7)

Screw fixation available with accessory (Fig.7)

- Capacidad de embornado / **Connecting wire:**

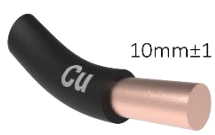
	Capacidad de embornado / Connecting wire Utilizar cables de cobre / Copper wires only		Conexión / Wiring
	Métrico / Metric	AWG	
1 Cable / Wire	0,75...16mm ² Rígido / Solid 0,75...16mm ² Flexible / Stranded	#8....18 AWG Rígido / Solid #8....18 AWG Flexible / Stranded	
2 Cables / Wires (Misma sección y tipo) (Same cross-section and type)	0,75...10mm ² Rígido / Solid 0,75...6mm ² Flexible / Stranded	#8....18 AWG Rígido / Solid #10....18 AWG Flexible / Stranded	

- El uso de terminales de conexión puede permitir aumentar la sección de cable de embornado.

- The use of wire-end terminals may allow to increase the connecting wire section.

- Montaje de terminales recomendado:

- Wire-end terminals recommended mounting:



- El uso de terminales podría no garantizar el grado de protección IP20.

- The use of wire-end terminals could not guarantee the IP20 protection degree.

- Se recomienda el uso de punteras en cables de sección $\leq 2,5\text{mm}^2$

-Is recommended use of ferrules in wires with section $\leq 2,5\text{mm}^2$



- El producto se suministra con los bornes abiertos y listos para conectar.

- The product is delivered with the terminals opened and ready to connect.

Par de apriete en bornes: **2 ... 2,5 Nm / 18 ... 22 lb.in**
Tornillos con huella combinada: **RANURA + PZ2**

Tightening torque on terminals: **2 ... 2,5 Nm / 18 ... 22 lb.in**
Screws with a combined head: **SLOT + PZ2**

Posibilidad de uniones multipolares mediante accesorios de fácil montaje:

Easy multipolar assembly for end users by the use of accessories:

Ver referencias en GAMA. Ver montaje en fig. nº 1

See references on RANGE. See assembly in fig. nº 1





PMX-CC

BASES INDUSTRIALES PARA FUSIBLES CILÍNDRICOS
INDUSTRIAL FUSEHOLDERS FOR CYLINDRICAL FUSELINKS

<p>Bases con indicador luminoso de fusión: Neón versión estándar 120...600V AC</p>	<p>Fuse holders with fuse indicator: Neon standard version 120...600V AC</p>
<p>Zona especial precintado base con cable de $\varnothing 1,5\text{mm}$.</p>	<p>Especial zone for sealing with A $\varnothing 1,5\text{ mm WIRE}$.</p>
<p>Todas las versiones van equipadas con porta-etiquetas para la identificación del circuito.</p> <ul style="list-style-type: none"> Tamaño adecuado de etiqueta: 11x9 mm Ver montaje en Fig. nº2. 	<p>All the versions with label holder for a better circuit identification.</p> <ul style="list-style-type: none"> Suitable size for label: 11x9 mm See operation in Fig. nº 2.
<p>Disponible accesorio para bloqueo de la base mediante candado. (Máximo 3 candados de $\varnothing 3\text{mm}$)</p> <ul style="list-style-type: none"> Ver montaje en Fig. Nº3 	<p>Accessory available to lock the fuse holder by a padlock. (Máx. 3 padlocks of $\varnothing 3\text{mm}$)</p> <ul style="list-style-type: none"> See operation in Fig. nº 3

PESOS

WEIGHT

	ESTANDAR / CON INDICADOR STANDARD / WITH INDICATOR
1P	57 gr.
2P	114 gr.
3P	171 gr.

- Pesos de producto sin embalaje. [Products without packing.](#)

DIMENSIONES

DIMENSIONS

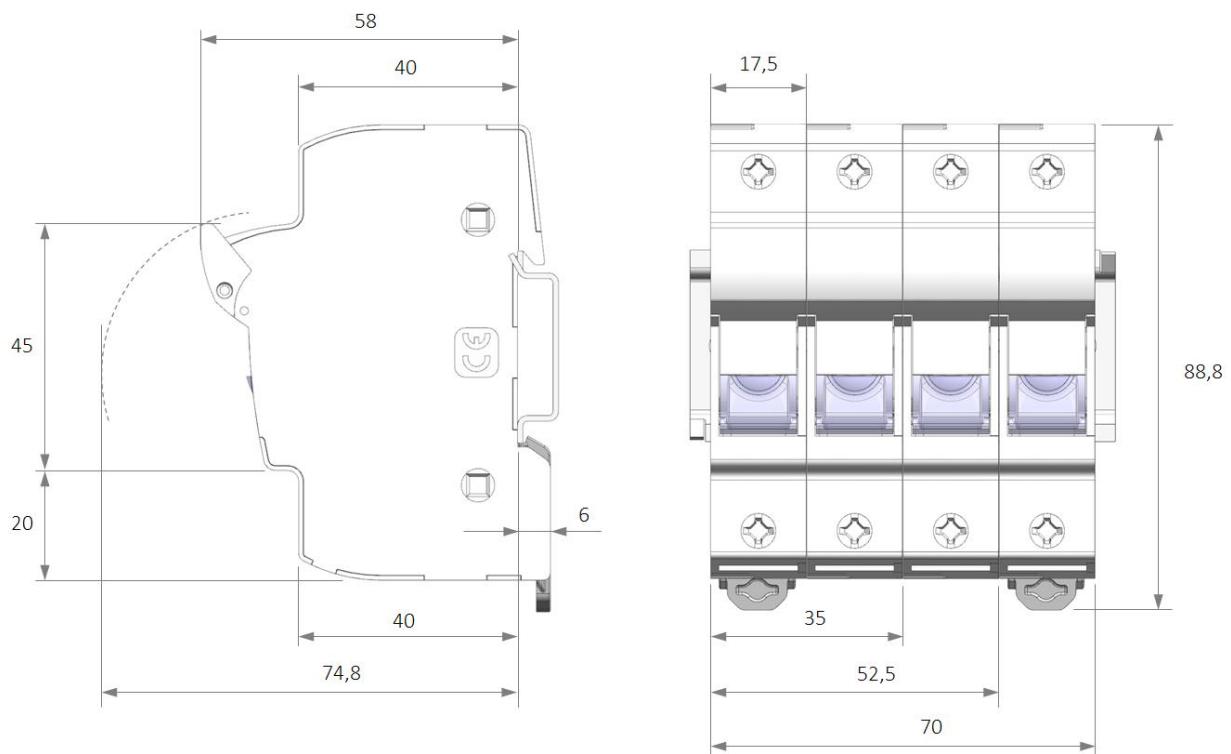



PMX-CC

BASES INDUSTRIALES PARA FUSIBLES CILÍNDRICOS
INDUSTRIAL FUSEHOLDERS FOR CYLINDRICAL FUSELINKS

POSICION DEL FUSIBLE

FUSE-LINK POSITION

Posición correcta de uso del fusible.
Correct use position of the fuse-link.

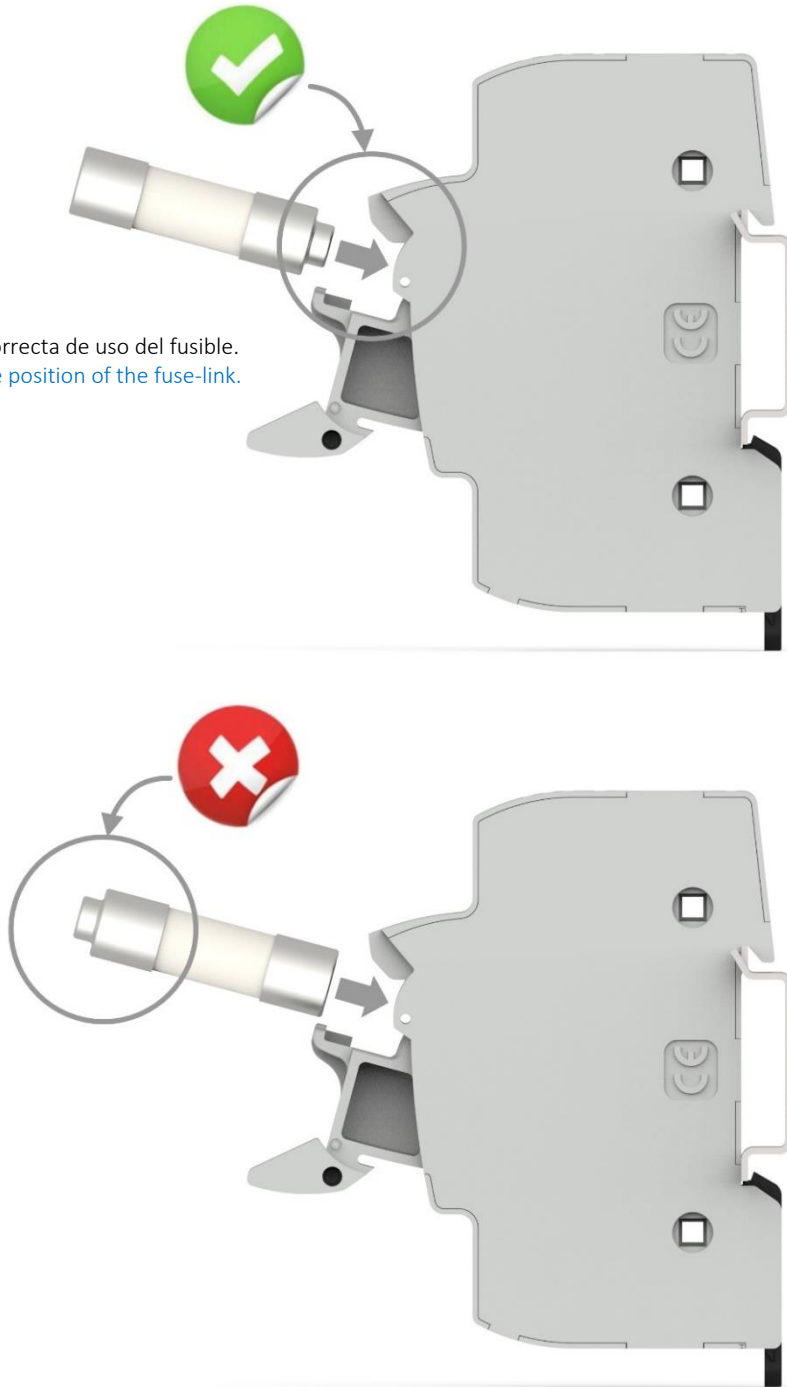

La base portafusibles está diseñada para no permitir el uso de fusibles en esta posición.
The fuse holder is designed to not allow to use the fuse-link in this position.





PMX-CC

BASES INDUSTRIALES PARA FUSIBLES CILÍNDRICOS
 INDUSTRIAL FUSEHOLDERS FOR CYLINDRICAL FUSELINKS

Fig. 1 Ensamblado multipolar

▪ Sistema estándar de DF, 2 clips y 1 pasador entre cada unión entre polos.

Fig.1 Multipolar assembly

▪ Standard system by DF, 2 clips and 1 pin for each union between poles.

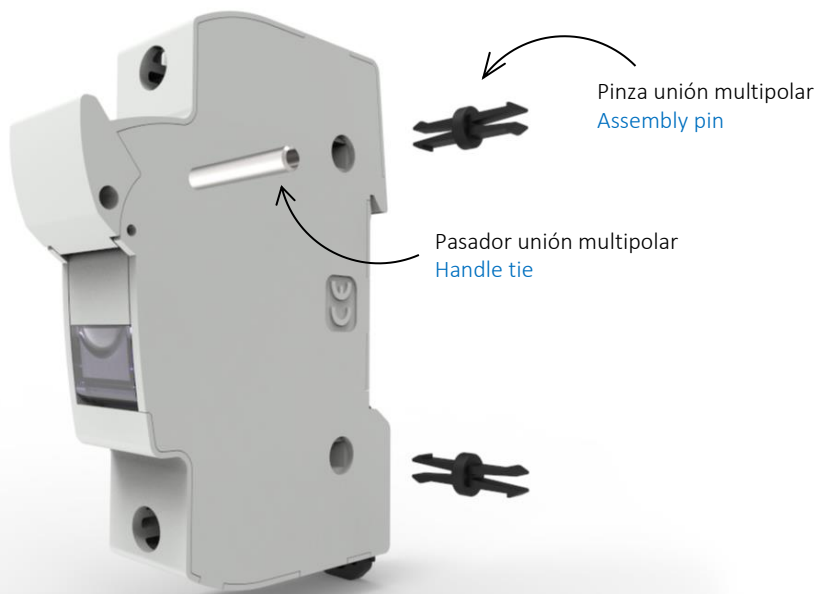

Fig. 2 Identificación con etiqueta

▪ Abrir la pieza porta-etiquetas con la base totalmente cerrada, posicionar la etiqueta en el interior y cerrar.

Fig.2 Identification by label

▪ Open the label-holder part with the fuseholder closed, put on the label and close it.

Medidas etiqueta
 Label measures

11x9mm

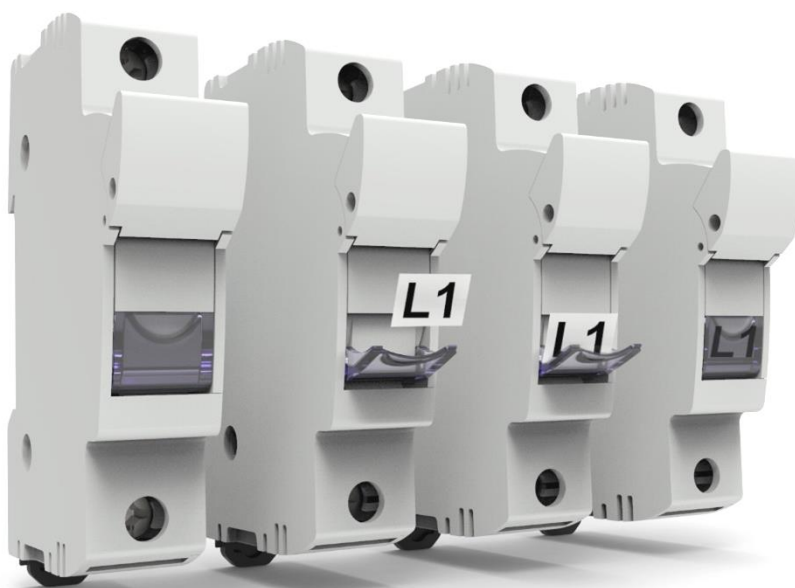



PMX-CC

BASES INDUSTRIALES PARA FUSIBLES CILÍNDRICOS
INDUSTRIAL FUSEHOLDERS FOR CYLINDRICAL FUSELINKS

Fig. 3 Bloqueo de la base

▪ Sistemas para evitar la maniobra y conexión, con la base abierta o cerrada.

Fig.3 Lock of the fuseholder

▪ Systems to avoid the operation and connection when the fuseholder is open or closed.

La base PMX permite ser precintada mediante un alambre.
PMX Bases allow to be sealed by a wire.



El sistema de bloqueo PMX impide el uso no autorizado de la base.
PMX locking system prevents unauthorized use of the base.

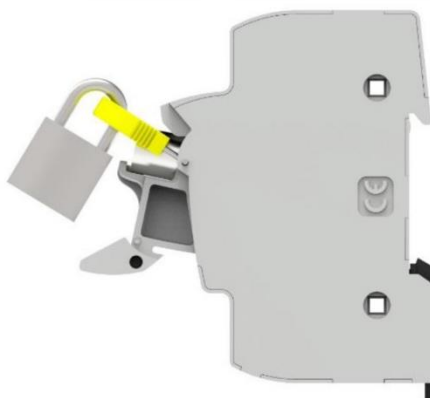

1

Abrir la base y extraer el fusible.
Open the fuseholder and extract the fuse.

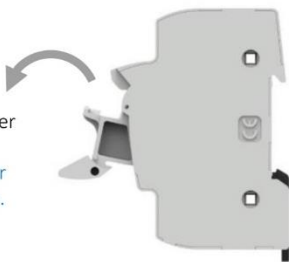

2

Introducir el bloqueo en los agujeros indicados.
Introduce the lock into the indicated holes.



3

Introducir el fusible en la base y empujar el bloqueo.
Introduce the fuselink into the fuseholder and push the lock.



4

Poner el candado. Ahora la base está bloqueada.
Put the padlock. Now the fuseholder is locked.

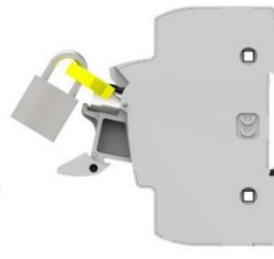



PMX-CC

BASES INDUSTRIALES PARA FUSIBLES CILÍNDRICOS
INDUSTRIAL FUSEHOLDERS FOR CYLINDRICAL FUSELINKS

Fig. 4 Protección IP20 especial

- Posicionar el reductor en la entrada del cable cuando se necesite conseguir un grado de protección IP20 con cables finos.

Montaje manual
Manual assembly



Fig.4 Special IP20 protection

- Position the reducer accessory at the terminals when an IP20 protection is required with thin cables.

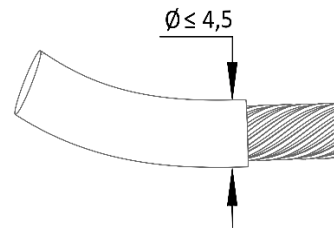

Para obtener un grado IP20 con protección de cable de $\varnothing \leq 4,5\text{mm}$, utilizar el **accesorio de protección especial**.

To obtain an IP20 rating with cable protection of $\varnothing \leq 4.5\text{mm}$, use the **special protection accessory**.

Fig. 5 Accesorio separador fases

- El accesorio aumenta la distancia entre fases en conjuntos multipolares.

Montaje manual
Manual assembly



Fig.5 Phase separators accessory

- The accessory increases the distance between phases in multipolar assemblies.





PMX-CC

BASES INDUSTRIALES PARA FUSIBLES CILÍNDRICOS
INDUSTRIAL FUSEHOLDERS FOR CYLINDRICAL FUSELINKS

Fig. 6 Accesorio protección tornillos

▪ Accesorio de protección que evita la manipulación de los tornillos y mejora el grado de protección.

Fig.6 Screws protection accessory

▪ Protection accessory to avoid the screws manipulation and improve the protection degree.



Montaje manual
Manual assembly

Fig. 7 Accesorio fijación tornillo

▪ Montar el accesorio con los tornillos y después montar la base (existentes diferentes accesorios en función de los polos a fijar)

Fig.7 Screw fixation accessory

▪ First mount the accessory with screws, then mount the fuseholder (there are available different accessories depending the number of the fuseholder)

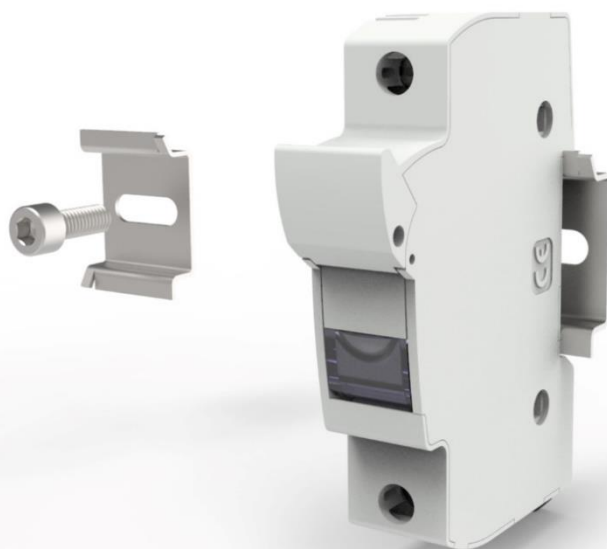



PMX-CC

BASES INDUSTRIALES PARA FUSIBLES CILÍNDRICOS
INDUSTRIAL FUSEHOLDERS FOR CYLINDRICAL FUSELINKS

Fig. 8 Instrucciones reemplazo indicador de fusión

Fig.8 Fusing Indicator replacement instructions

Abrir la base portafusible.
Open the fuseholder.



Usando un destornillador plano, extraer la tapeta con una ligera rotación de la herramienta.
Using a flat screwdriver, remove the cover with a slight rotation of the tool.

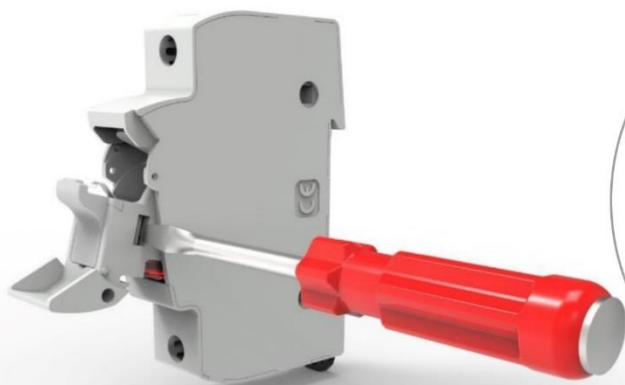

Cambiar el indicador de fusión. Introducir con un ligero ángulo la tapeta en el tirador.
Replace the fusing indicator. Enter the cover on the handle with a slight angle.

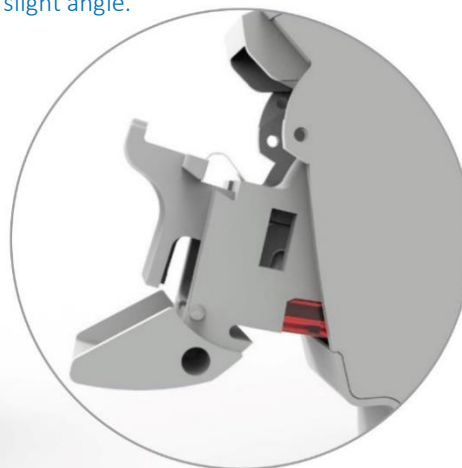
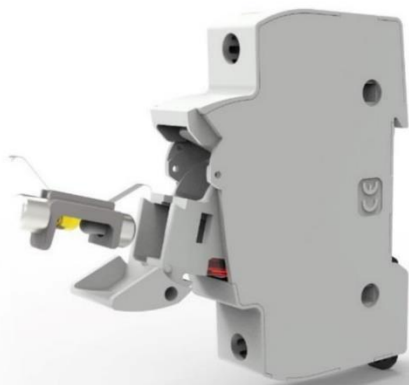

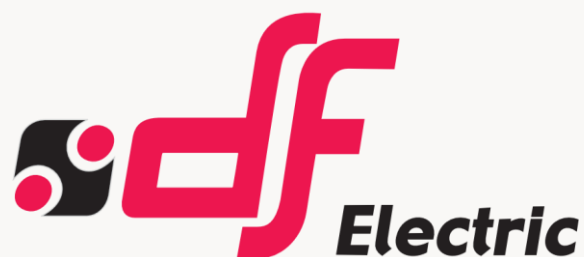

PROTECTING THE WORLD

OFICINA CENTRAL Y FÁBRICA HEAD OFFICE AND FACTORY

SILICI, 67-69
08940 CORNELLA DE LLOBREGAT
BARCELONA · SPAIN
Tel. +34 93 377 85 85
Fax +34 93 377 82 82

VENTAS INTERNACIONAL INTERNATIONAL SALES

Tel. +34 93 475 08 64
Fax +34 93 480 07 75
export@dfelectric.es

VENTAS NACIONAL NATIONAL SALES

Tel. 93 475 08 64
Fax 93 480 07 76
comercial@dfelectric.es

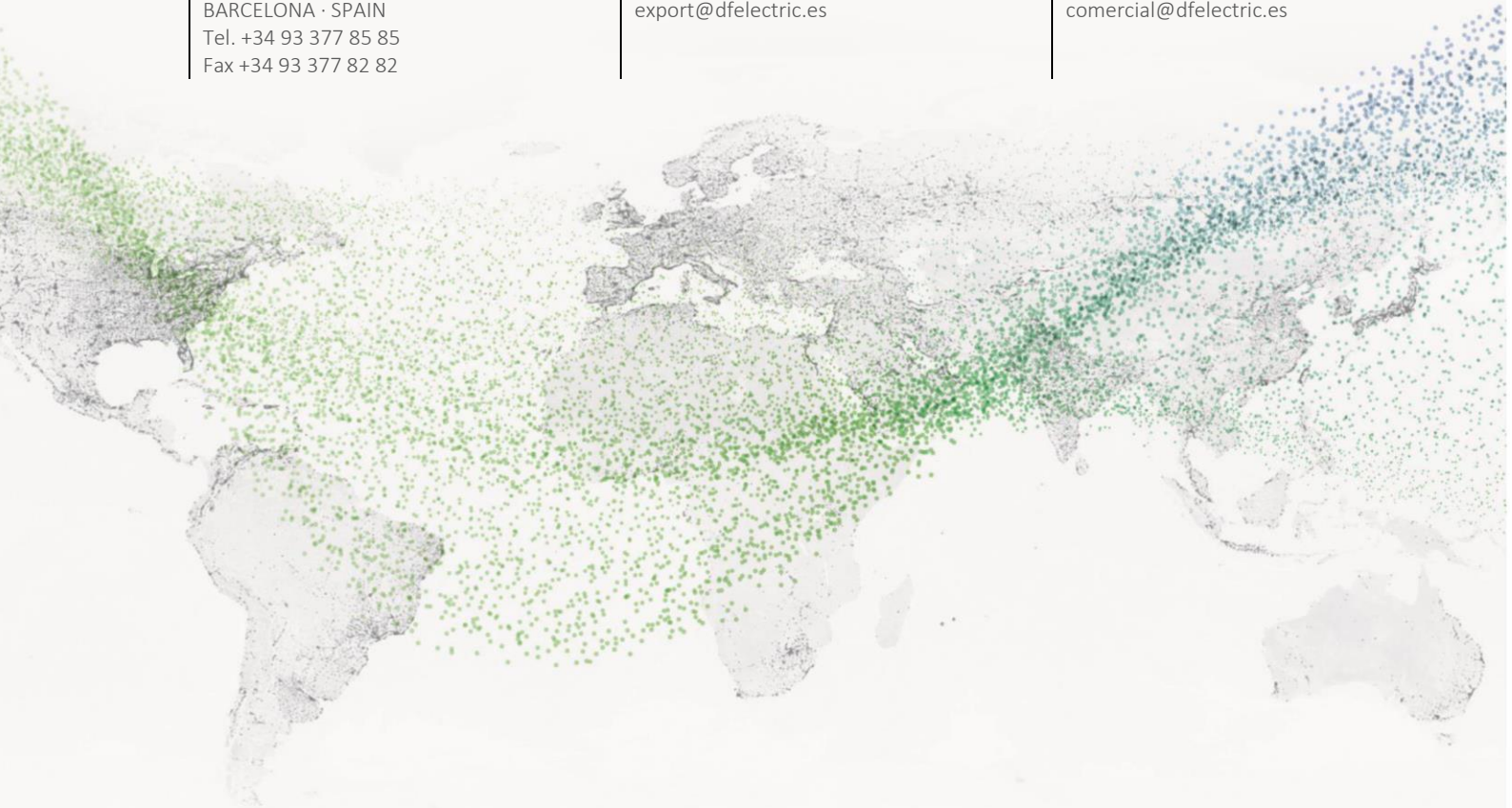

www.dfelectric.es

